

南京拓品微电子有限公司

NanJing Top Power ASIC Corp.

DATASHEET

TP5000X

(2A switching 3.6V/4.2V /4.35V lithium battery

Charger)

Description

TP5000X is a switching buck single manganese lithium battery charge management chip. Its ESOP8 package with simple peripheral circuit, making the TP5000X is ideal for portable equipment large current charging management applications. Meanwhile, TP5000X built-in input overcurrent, undervoltage protection, over temperature protection, short circuit protection, battery temperature monitoring, reverse battery protection, shutdown OVP function due to excessive input power.

TP5000X has a wide input voltage, divided into three stages Trickle pre-charge, constant current, constant voltage trickle charge the battery pre-charge current, constant current charging current adjusted through an external resistor, the maximum charging current of 2A. TP5000X switching frequency of 800kHz operating mode so that it can use smaller external components and smaller heat remains in the high current charging. TP5000X Built-power the PMOSFET, anti-intrusion circuit, so there is no need anti-intrusion perimeter protection Schottky diodes.

Characteristic

- Single manganese lithium battery charge, three voltage specifications :3.6V,4.2V, 4.35V
- Built-in power MOSFET, switching mode, The devices less heat, simple peripheral
- Power adaptive function
- Input power OVP function
- Programmable charge current, 0.1A--2A
- Eliminates the need for an external Schottky diode anti-intrusion
- Wide operating voltage up to 9V
- Two LED charge status indicator
- Chip temperature protection, overcurrent protection, undervoltage protection
- Battery temperature protection, reverse battery shutdown, short-circuit protection
- Switching frequency 800KHz, available inductor 2.2uH-10uH
- Automatic recharge function

- Less than 1% of the charging voltage control precision
- Paragraph Trickle, constant current, constant voltage charging to protect the battery
- ESOP8 package

Absolute Maximum Ratings

- Input supply voltage (VIN): 9V
- BAT:0V ~ 9V
- BAT short duration: continuous
- Maximum Junction Temperature: 145°C
- Operating ambient temperature range: -20°C to 85°C
- Storage temperature range: -30°C ~ 100°C
- Lead Temperature (Soldering, 10 sec): 260°C

Application

- Portable devices, various chargers
- PDAs, mobile cellular phone
- Tablet PC, Miner's lamp
- Power tools

Typical applications

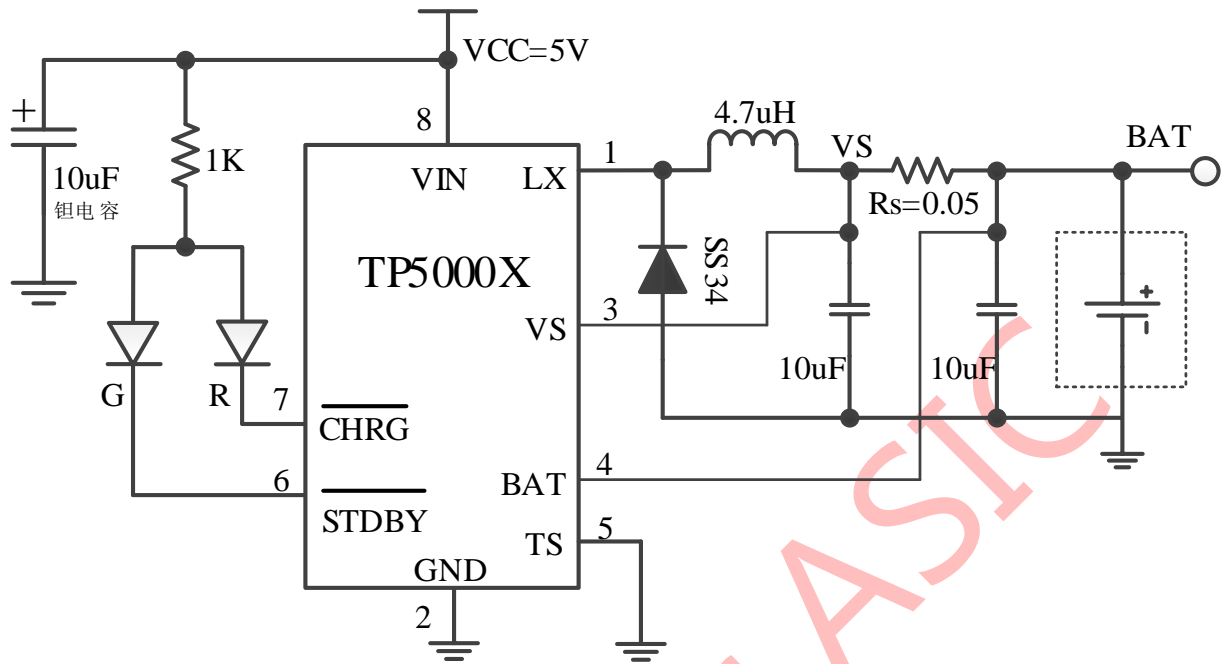

Figure 1 TP5000X 4.2V lithium-ion battery charging 2A Application Diagram

Package / Ordering Information

<p>8-pin ESOP8 package</p> <p>(Heat sink grounding can not be connected to other potential)</p> <p>YYWW: Production year and week</p>	<p>TP5000X-3.6V-ESOP8</p> <p>TP5000X-4.2V-ESOP8</p> <p>TP5000X-4.35V-ESOP8</p> <p>AYYWWX→4.35V BYYWWX→4.2V CYYWWX→3.6V</p> <p>Product pictures</p>
--	--

TP5000X functional block diagram

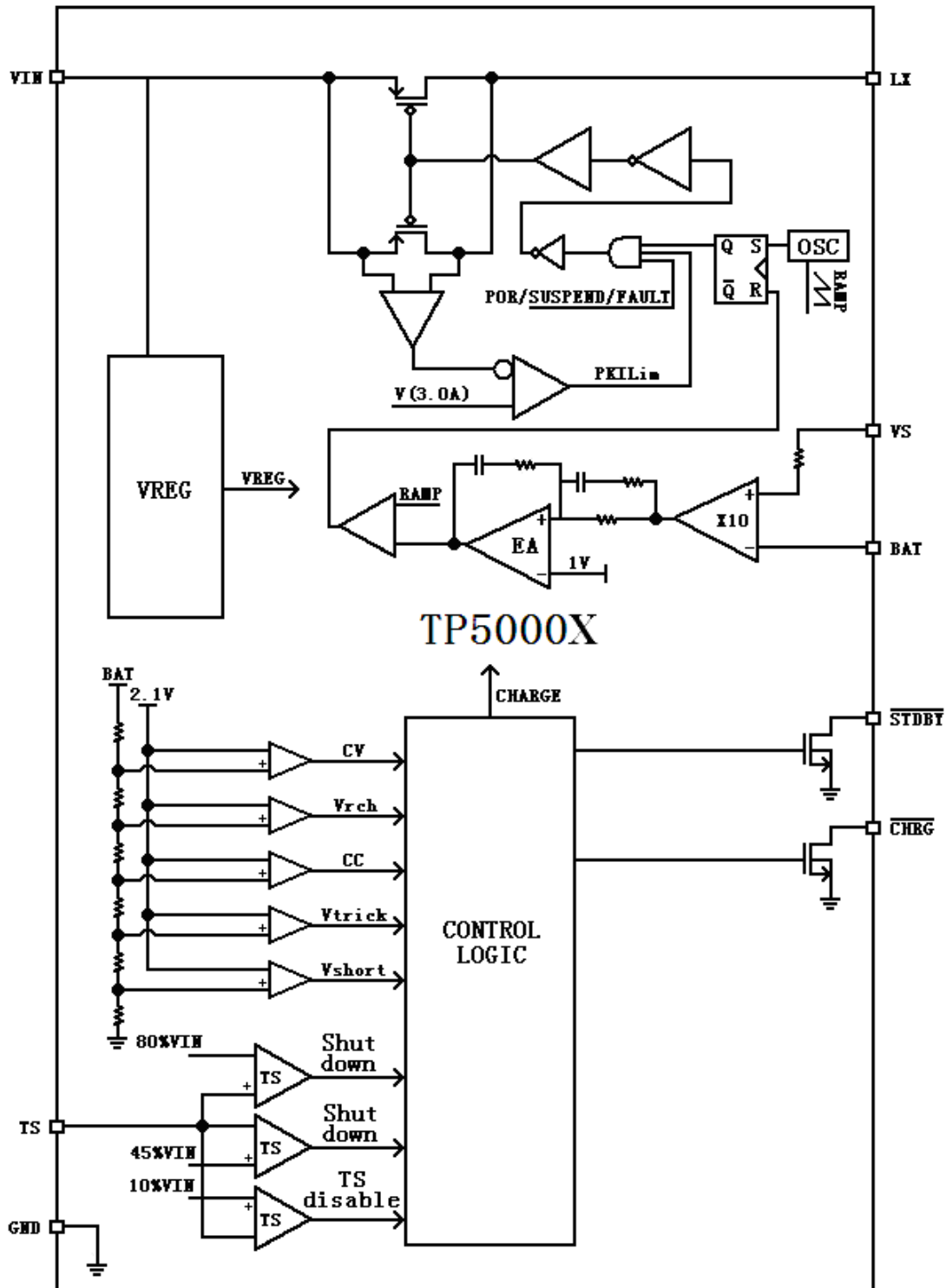

Figure 2 Functional block diagram of TP5000X

Electrical characteristics

Table 1 TP5000X electrical characteristics of energy parameters

Where a sign ● denotes specifications which apply over the full operating temperature range, otherwise refers only to TRAR = 25 ° C. VIN = 5V, unless otherwise noted.

Symbol	Parameter	Condition		Min	Typ	Max	Unit
VIN	Input supply voltage		●	4.5	5	9.0	V
ICC	Input supply current	Charge mode, RS=0.1Ω	●		250	500	μA
		Standby mode (Charge termination)	●		180	250	μA
		Shutdown mode (CS=GND, VIN<VBAT, or VIN<VUV)	●		180	250	μA
VFLOAT	Charge cut-off voltage	3.6V Lithium ion battery		3.564	3.6	3.636	
		4.2V Lithium ion battery		4.158	4.2	4.242	V
		4.35V Lithium ion battery		4.306	4.35	4.394	V
IBAT	BAT Pin Current: (Current-mode test conditions CS=VIN、 Battery voltage=3.8V)	RS=0.1Ω, Constant current mode	●	850	1000	1150	Ma
		RS=0.067Ω, Constant current mode	●	1300	1500	1700	Ma
		Standby mode, VBAT=4.2V	●	0	-4	-6	Ua
		VIN=0V, VBAT=4.2V	●	0	-4	-6	Ua
F	Oscillation Frequency			650	800	950	KHz
DMAX	Maximum duty cycle				100%		
DMIN	Minimum duty cycle			0%			
VTRIKL	Trickle charge threshold voltage (4.2V)	RS=1Ω, VBAT Rise		2.7	2.9	3.0	V
VTRHYS	Trickle charging hysteresis voltage	RS=1Ω		60	80	100	Mv
VUV	VIN Undervoltage Lockout threshold	VIN From low to high	●	3.5	3.7	3.9	V
VUVHYS	VIN Undervoltage Lockout hysteresis		●	150	200	300	Mv
VADPT		VIN From high to low		4.1	4.3	4.5	V
VASD	VIN-VBAT Lockout threshold voltage	VIN From low to high		60	100	140	mV
		VIN From high to low		5	30	50	mV
VCHRG	CHRG Pin output low voltage	I _{CHRG} =5mA			0.3	0.6	V
VSTDBY	STDBY Pin output low voltage	I _{STDBY} =5mA			0.3	0.6	V
VTEMP-H	TEMP Pin high-end shutdown voltage				>80	82	%*VIN
VTEMP-L	TEMP Pin low-end shutdown voltage			43	<45		%*VIN
ΔVRECHRG	Rechargeable battery threshold voltage	VFLOAT-VRECHRG		50	80	100	mV

T_{LIM}	Chip protection temperature				145		$^{\circ}C$
R_{ON}	Power FET on-resistance				260		$m\Omega$
t_{ss}	Soft-start time	$I_{BAT}=0$ to $I_{BAT}=0.1V/R_s$			20		μS
$t_{RECHARGE}$	Recharge Comparator Filter Time	V_{BAT} High to Low		0.8	1.8	4	mS
t_{TERM}	Termination Comparator Filter Time	I_{BAT} Below $C/10$		0.8	1.8	4	mS

Typical performance indicators

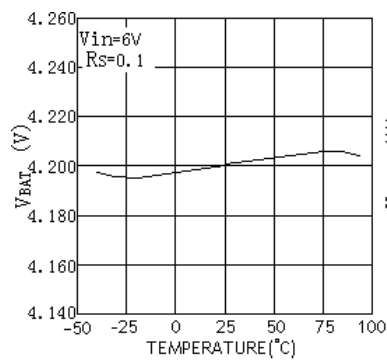

Figure 3

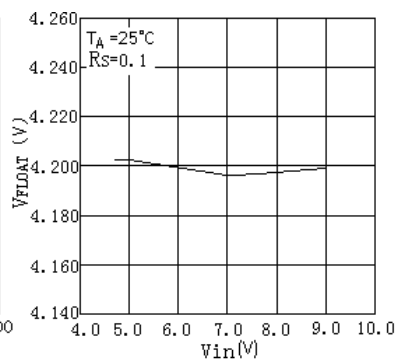

Figure 4

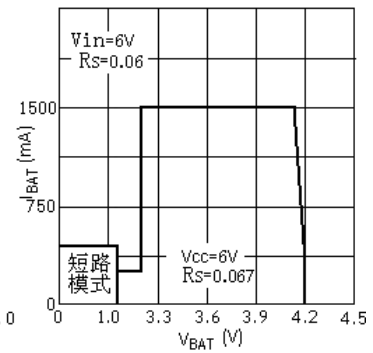

Figure 5

Figure 3: Cut-off voltage and ambient temperature relationship

Figure 4: The date of the relationship between battery voltage and supply voltage

Figure 5: Charging current and battery voltage relationship

Pin Function

LX (Pin 1): built-in the PMOSFET power pipe drain connection. LX is TP5000X the current output terminal and is connected to the external inductor as the input terminal of the battery charging current.

GND (Pin 2): Power Ground.

VS (Pin 3): Output current sense positive input terminal.

BAT (Pin 4): battery voltage detection terminal. To the positive terminal of the battery is connected to this pin.

TS (Pin 5): The battery temperature detection input. TS pin to the NTC (negative temperature coefficient thermistor) sensor output terminal of the battery. If the TS pin voltage is less than 45% of the input voltage or greater than 80% of the input voltage, which means that the battery temperature is too low or too high, the charging is suspended. If TS is directly tied to GND, battery temperature detection function is canceled, the other charging function properly.

$\overline{\text{STDBY}}$ (Pin 6): Battery Charge complete indication end. When the battery is fully charged, the internal switch is pulled low, the charging is completed. In addition, the pin will be in a high impedance state.

$\overline{\text{CHRG}}$ (Pin 7): Charge indicator status.

Charger to charge the battery, pin internal switch pulled low, indicating that charging is in progress; otherwise the pin is in a high impedance state.

VIN (Pin 8): the positive input terminal of the input voltage. The voltage on this pin for internal circuit power supply, and the VIN changes in the range of 4.5V to

9V and a 10 μ F tantalum capacitor bypass. When the VIN and V_{BAT} differential pressure is lower than 50mv, TP5000X enter shutdown mode, the dropped 4 μ A so I_{BAT}.

Operational Principle(4.2V)

TP5000X is designed specifically for single 4.2V lithium-ion battery switching current charger chip, the use of the power transistors of the chip's internal battery trickle, constant current and constant voltage charging. The charging current can be set with an external resistor programming, maximum continuous charge current up to 2A, and does not require additional anti-intrusion diode. TP5000X consists of two open-drain output status outputs, charge status output $\overline{\text{CHRG}}$ and the battery is fully charged status outputs $\overline{\text{STDBY}}$.

Chip power management circuitry automatically reduces the charge current when the chip junction temperature exceeds 145 °C, this feature allows users to maximize the use of the power handling capability of the chip, and do not have to worry about the chip overheating and damage to the chip or the external components.

When the input voltage is greater than the chip start-up threshold voltage and chip enable input the high termination or floating, TP5000X start charging the

battery, $\overline{\text{CHRG}}$ pin output low, which means that charging is in progress. If the lithium-ion battery voltage is below 2.9V battery trickle charger with a small current pre-charge (pre-charge current adjustable via an external resistor). Constant charge current is determined by the resistance between the VS pin and VBAT pin. When the lithium-ion battery

voltage is close to 4.2V, from the charge cut-off voltage of about 50mV (depending on the circuit connection resistance and the internal resistance of the battery voltage), the charging current decreases, TP5000X enters the constant charge mode. The end of the charge cycle when the charge current is reduced to the cut-off current, $\overline{\text{CHRG}}$ Pin output

high-impedance state, $\overline{\text{STDBY}}$ Pin output low.

When the battery voltage falls below the recharge threshold, automatically starts a new charge cycle. Chip precision internal voltage reference, error amplifier and the resistor divider network to ensure the accuracy of the cut-off voltage of the battery terminal within + -1%, to meet the charging requirements of the lithium-ion battery and lithium iron phosphate. Power-down when the input voltage or the input voltage is lower than the battery voltage, the charger enters a low power shutdown mode, no external anti-intrusion diode, battery leakage from the chip close to 4uA.

Charge current setting

Battery charging current I_{BAT} , is determined by the external current sense resistor R_s . Across this resistor (R_s) to adjust the threshold voltage and constant current to determine the ratio of the charging current, the voltage across the resistor (R_s) under a constant current state as 100mV.

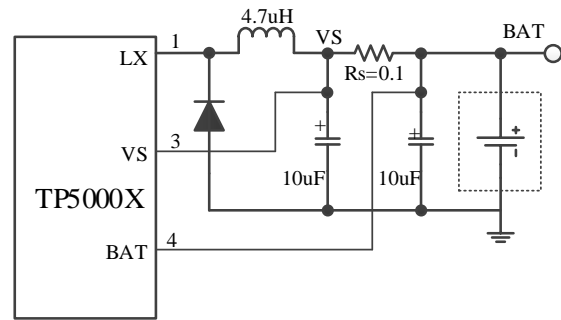

Figure6 Set charging current

Setting resistor and the charge current using the following formula to calculate

$$\text{the: } R_s = \frac{0.1V}{I_{\text{BAT}}} \text{ (Current units A, resistance}$$

units Ω).

Examples: Need to set the charging current is 1A, into the formula $R_s=0.1 \Omega$

Table 2 shows some of the settings corresponding to the type of current resistor R_s , fast and easy to design the circuit.

Table 2: R_s and its corresponding constant current charge current

R_s (Ω)	I_{BAT} (mA)
1	100
0.2	500
0.1	1000
0.067	1500
0.05	2000

Charge termination

Constant voltage phase, when the charge current drops to 1/10 of the maximum constant value, the charge cycle is terminated. This condition is detected by using an internal comparator filter to monitor the pressure drop R_s . When the voltage across R_s Poor to time exceeds 10mV or less (typically 1.8ms), charging is terminated. The charging current is off, TP5000 enters standby mode, the input

supply current drops to 170 μ A, Battery drain current outflow about 4 μ A. In standby mode, the TP5000X continuous monitoring of the BAT pin voltage. If the lithium-ion battery to this voltage drops below 4.12V rechargeable switches below the limit, the new charge cycle begins and again supply current to the battery.

Charging status indicator

TP5000X has two open-drain status output terminal, $\overline{\text{CHRG}}$ and $\overline{\text{STDBY}}$.

When the charger is charging, $\overline{\text{CHRG}}$ is pulled low, in other states, $\overline{\text{CHRG}}$ in a high-impedance state. When the battery temperature is outside the normal temperature range, $\overline{\text{CHRG}}$ and $\overline{\text{STDBY}}$ the pins are high impedance. When the status indicator is not used, the unused pin is connected to the ground.

Table 3: charging indicator status

Green $\overline{\text{STDBY}}$	Red $\overline{\text{CHRG}}$	State of charge
off	on	Is charging state
on	off	The battery is fully state
off	on	VADPT
off	off	Under-voltage, battery temperature is too high, too low fault condition or without battery access. (TS used)
Green light, red light flashes T=0.5-2S		BAT Connect the 10u capacitors, battery standby state (TS connected to ground)

Battery over temperature protection

In order to prevent the temperature is too high or too low the damage caused by the battery, TP5000X integrated battery temperature detection circuit. The battery temperature detection is achieved by measuring TS pin voltage, the voltage of the TS pin is realized by the NTC thermistor inside the battery, and a resistor divider network, as shown in Figure 7. TP5000X two threshold TS pin voltage with the chip and compared to confirm that the battery temperature is outside the normal range. Within TP5000X is fixed to be fixed in. If the TS pin voltage, it means that the battery temperature is too high or too low, the charging process will be suspended; TS pin voltage between and the charge cycle resumes. If the TS pin to ground, the battery temperature detection function will be disabled.

Example: room temperature 25 $^{\circ}\text{C}$ under $R_{\text{NTC}} = 10\text{k}$, the set protection temperature 60 $^{\circ}\text{C}$, 60 $^{\circ}\text{C}$ under $R_{\text{NTC}} = 3\text{k}$, then the calculation was $R_{\text{NTC}} = 3.6\text{k}$, the NTC resistor divider ratio of 45% of the supply voltage, ie 60 $^{\circ}\text{C}$ TP5000X stopcharge.

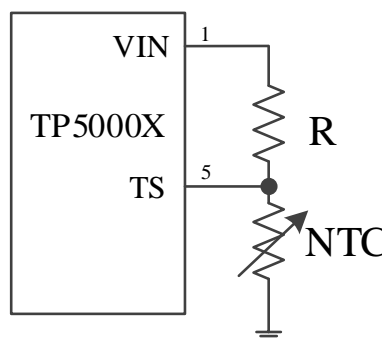

Figure 7 NTC connection diagram

In ESOP8 package applications, the TS side can be used for enable control. Connect the TS to the MCU control terminal, and the TS is pulled to GND for the active state. When the TS is pulled to the Vin voltage, it is in the shutdown state.

Thermal limitation inside the chip

If the die temperature rises above a preset value of approximately 145 °C, an internal thermal feedback loop will reduce the set charge current. This feature prevents the TP5000X from overheating and allows the user to increase the upper limit of the power handling capability of a given board without risking damage to the TP5000X. The charging current can be set according to a typical (rather than worst case) ambient temperature, provided that the charger will automatically reduce the current under worst-case conditions.

Current limit and output

short circuit protection

TP5000X integrates a variety of protections, and the chip input end limits the maximum peak current of 3.5A to prevent chip damage caused by excessive current. When the output voltage is lower than about 1.2V, the chip enters short-circuit protection mode, and the chip input current is limited to 10% of the maximum peak current, about 350mA. The amount of current varies with the input voltage.

Power adaptive function

When Vin drops to 4.4V, the adaptive

circuit starts; automatically reduces the output current until VCC no longer decreases; this function can avoid power reset or restart, when the high-current charging system uses USB, low-power power adapter or solar battery as the power source

Power supply voltage OVP

(overvoltage protection)

When the Vin voltage is higher than 9.5-10V, the chip enters the overvoltage protection state. In this state, the chip stops charging and the indicator light is completely off. In this state, the maximum withstand voltage of the chip can reach 12V. If the customer's working environment needs to withstand 12V voltage, it is recommended that the customer connect 0.3-0.5 ohm power dissipation resistor at the power input end, as shown below.

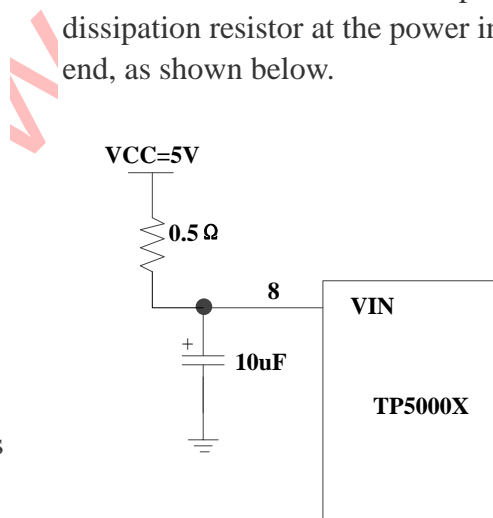

Package Description

8-pin ESOP8 package (mm)

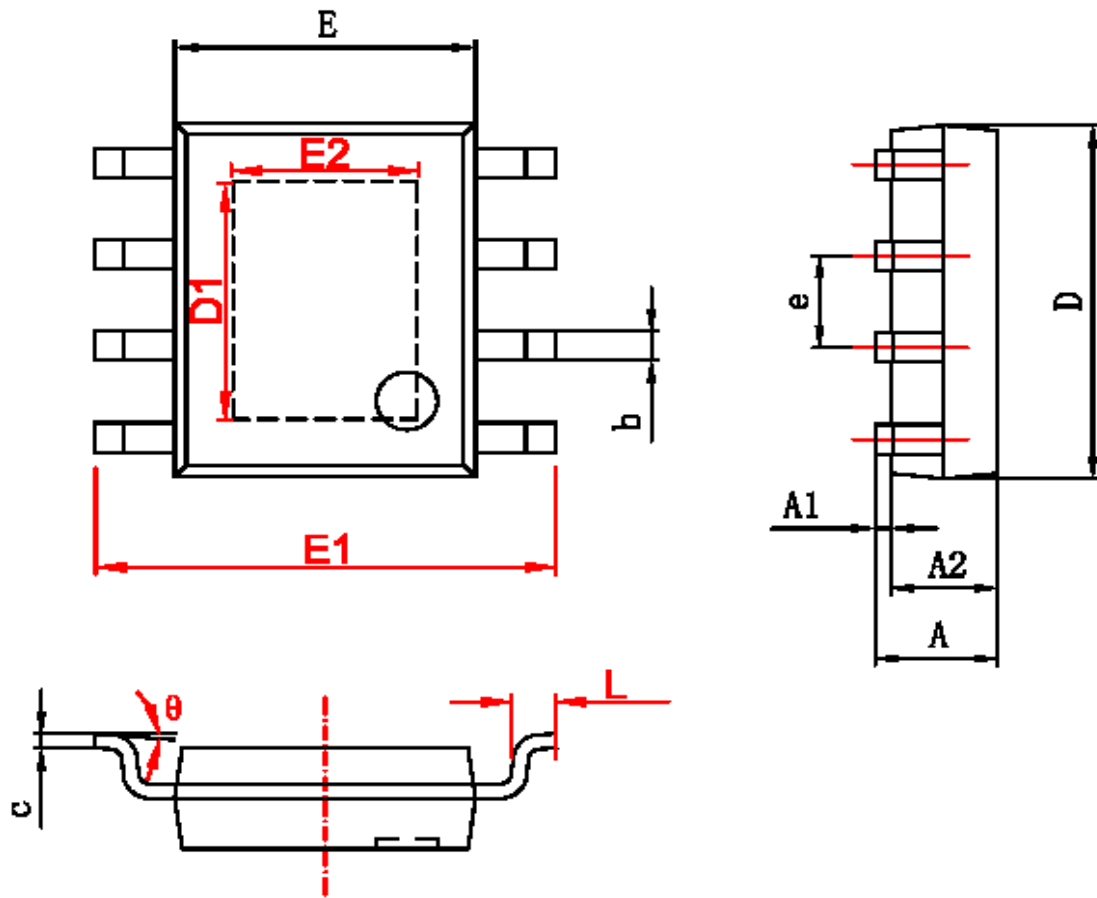

字符	Dimensions In Millimeters		Dimensions In Inches	
	Min	Max	Min	Max
A	1.350	1.750	0.053	0.069
A1	0.050	0.150	0.004	0.010
A2	1.350	1.550	0.053	0.061
b	0.330	0.510	0.013	0.020
c	0.170	0.250	0.006	0.010
D	4.700	5.100	0.185	0.200
D1	3.202	3.402	0.126	0.134
E	3.800	4.000	0.150	0.157
E1	5.800	6.200	0.228	0.244
E2	2.313	2.513	0.091	0.099
e	1.270 (BSC)		0.050 (BSC)	
L	0.400	1.270	0.016	0.050
θ	0°	8°	0°	8°

SOP8/PP(150mil) (12R)-C(90×90) PACKAGE OUTLINE DIMENSIONS

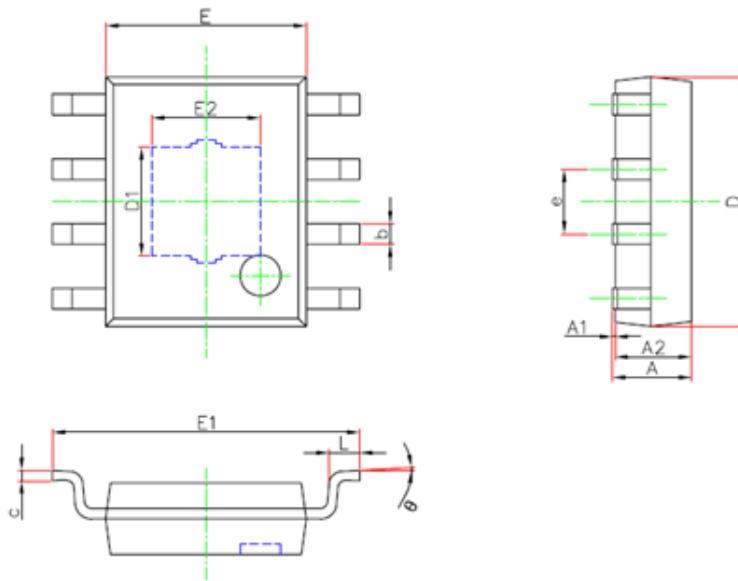

Symbol	Dimensions In Millimeters		Dimensions In Inches	
	Min.	Max.	Min.	Max.
A	1.300	1.700	0.051	0.067
A1	0.000	0.100	0.000	0.004
A2	1.350	1.550	0.053	0.061
b	0.330	0.510	0.013	0.020
c	0.170	0.250	0.007	0.010
D	4.700	5.100	0.185	0.201
D1	2.034	2.234	0.080	0.088
E	3.800	4.000	0.150	0.157
E1	5.800	6.200	0.228	0.244
E2	2.034	2.234	0.080	0.088
e	1.270(BSC)		0.050(BSC)	
L	0.400	1.270	0.016	0.050
θ	0°	8°	0°	8°

Notes for TP5000X use

- The circuit capacitance should be as close as possible to the chip.
- The VS end of the VIN end and BAT end use of tantalum capacitors, X5R or X7R level ceramic capacitors or electrolytic capacitors plus 0.1uF ceramic capacitor.
- The inductor selection of the current capacity is sufficient power inductor.
- The Schottky diode choose conduction voltage drop current capability greater than or equal to 2A Schottky diode.
- For VIN and LX should be wider than the ordinary signal lines through the traces of the current loop.
- Pay attention to the the capacitive grounding line node location, and should try to make the ground point focused, well-grounded.
- Use the chip in the high-current work, should be considered a good connection of the chips at the bottom of the heat sink and the PCB to ensure good heat dissipation.