

南京拓品微电子有限公司

NanJing Top Power ASIC Corp.

TP4056X
(1A Standalone Linear Li-Ion Battery Charger)

DESCRIPTION

The TP4056X is a complete constant-current/constant-voltage linear charger for single cell lithium-ion batteries. Its ESOP8 package and low external component count make the TP4056X ideally suited for portable applications. The TP4056X is designed to work within USB power specifications (wall adaptor or USB supply).

No external sense resistor or blocking diode is required due to its internal PMOSFET architecture and integrated reverse discharge protection. TP4056X limits the charge current based on die temperature during high power operation or high ambient temperature. The charge voltage is fixed at 4.35V or 4.2V, and the charge current can be programmed externally with a resistor. TP4056X automatically terminates the charge cycle when the charge current drops to 1/10th of the programmed value after reaching the final float voltage.

When input power supply is removed, TP4056X will enter a low current state with battery drain current less than 1uA. TP4056X can also enter a shut-down mode with power supply, lowering supply current to less than 70uA.

Other features include cell temperature monitor, under voltage lockout, automatic recharge and two LED status indication pins for charge termination and presence of an input voltage.

FEATURES

- Positive and negative electrodes of lithium battery reverse polarity protection
- Input terminal reverse polarity protection (Need to connect R_{CE} resistor)
- Power adaptation
- Programmable Charge Current Up to 1000mA
- Complete single-cell linear Li-Ion battery charger in ESOP8/EMSOP8 Package
- Constant-Current/Constant-Voltage operation with thermal regulation
- Preset 4.2V Charge Voltage with 1% Accuracy
- Automatic Recharge
- Automatic End-of-charge control
- UVLO
- Two Charge Status Output Pins
- C/10 Charge Termination
- 70uA Charge Current in Standby Mode
- 2.9V Trickle Charge Threshold
- Soft-Start Limits Inrush Current
- 8-Lead ESOP Package

ABSOLUTE MAXIMUM RATINGS

- Input Supply Voltage (V_{CC}): -6.5V~8V
- PROG: -0.3V~ $V_{CC}+0.3V$
- BAT: -4.35V~7V
- CHRG: -0.3V~10V
- STDBY: -0.3V~10V

- TEMP: -0.3V~10V
- CE: -6.5V~10V
- BAT Short-Circuit Duration: Continuous
- BAT Pin Current: 1200mA
- PROG Pin Current: 1200uA
- Maximum Junction Temperature: 145°C
- Operating Ambient Temperature Range: -40°C~85°C
- Storage Temperature Range: -65°C~125°C
- Lead Temp.(Soldering, 10sec): 260°C

APPLICATIONS

- Cellular Telephones, PDAs, GPS
- Digital Cameras, Portable Devices
- USB Bus-Powered Chargers, Charging Docks

COMPLETE CHARGE CYCLE
(1000mAh Battery)

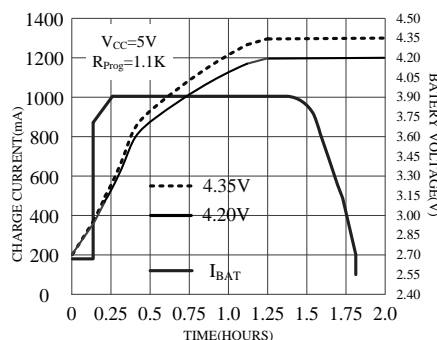

TYPICAL APPLICATIONS

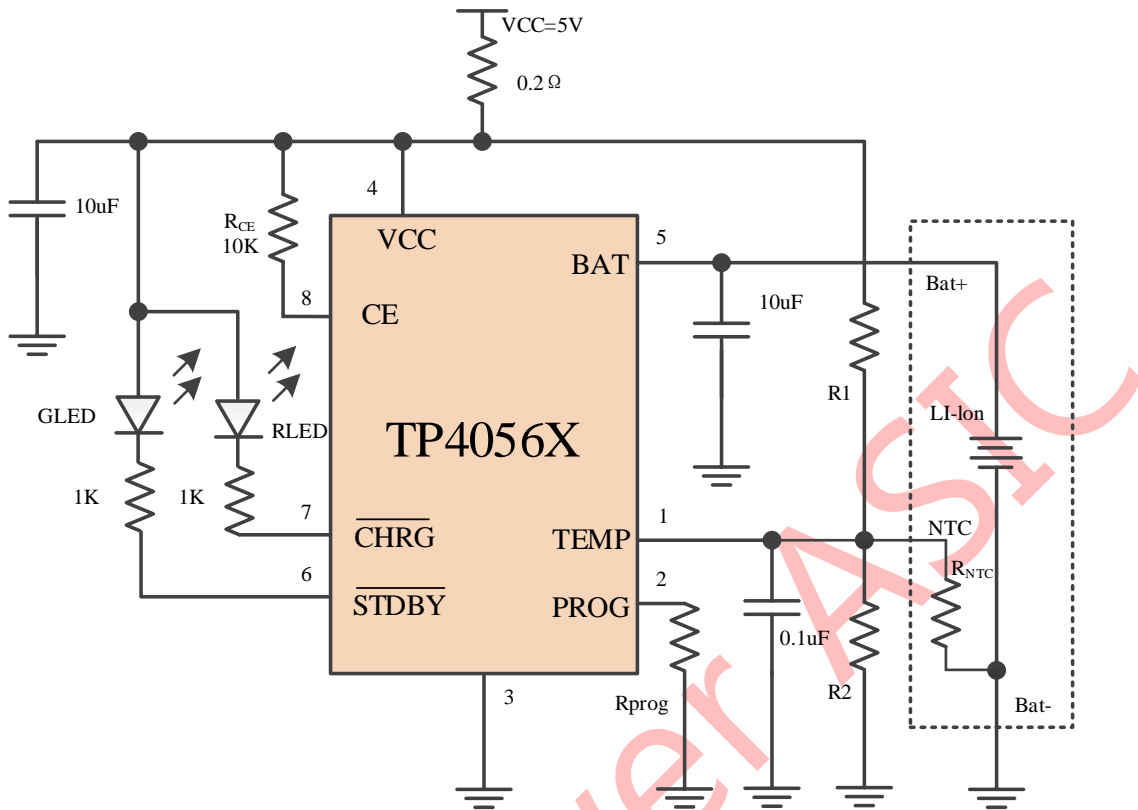

PACKAGE/ORDER INFORMATION

<p>ESOP8 (With heat sink on the bottom)</p>	<p>Order model</p> <p>TP4056X-435-ESOP8 TP4056X-42-ESOP8</p> <p>Device marking</p> <p>LOGO: TP4056 YYWWXa→4.35V YYWWX →4.20V</p>
<p>Physical picture</p>	<p>Seal description: LOGO, TP4056, X are fixed logos. YYWW is the production batch number, variable. a represents 4.35V product identification, and a is omitted to represent 4.2V product.</p>

ELECTRICAL CHARACTERISTICS

The ● denotes specifications which apply over the full operating temperature range, otherwise specifications are at TA=25°C, VCC =5V, unless otherwise noted.

SYMBOL	PARAMETER	CONDITIONS		MIN	TYP	MAX	UNITS
V _{CC}	Input Supply Voltage		●	4.0	5	8.0	V
I _{CC}	Input Supply Current	Charge Mode, R _{PROG} = 1.1K Standby Mode (Charge Terminated), Shutdown Mode (R _{PROG} Not Connected, V _{CC} < V _{BAT} , or V _{CC} < V _{UV})	● ● ●		150 70 70 70	500 120 120 120	μA μA μA μA
V _{FLOAT}	Regulated Output (Float) Voltage	0°C ≤ T _A ≤ 85°C		4.306 4.158	4.35 4.2	4.394 4.242	V
I _{BAT}	BAT Pin Current (Test condition: V _{BAT} =4.0V)	R _{PROG} =2.2k, Current Mode R _{PROG} =1.1k, Current Mode Standby Mode, V _{BAT} = V _{FLOAT} Shutdown Mode (R _{PROG} Not Connected) Sleep Mode, V _{CC} = 0V	● ● ● ● ●	425 850 0	500 1000 -2.5 ±1 -1	575 1150 -6 ±2 -2	mA mA μA μA μA
I _{TRIKL}	Trickle Charge Current	V _{BAT} < V _{TRIKL} , R _{PROG} = 1.1K	●	110	130	150	mA
V _{TRIKL}	Trickle Charge Threshold Voltage	R _{PROG} = 1.1K, V _{BAT} Rising		2.8	2.9	3.0	V
V _{TRHYS}	Trickle Charge Hysteresis Voltage	R _{PROG} = 1.1K		60	80	100	mV
V _{UV}	V _{CC} UVLO Voltage	V _{CC} from low to high	●	3.5	3.7	3.9	V
V _{UVHYS}	V _{CC} UVLO Hysteresis		●	150	200	300	mV
V _{ASD}	V _{CC} -V _{BAT} lockout threshold voltage	V _{CC} from low to high V _{CC} from high to low		60 5	100 30	140 50	mV mV
I _{TERM}	C/10 termination current threshold	R _{PROG} = 2.4K R _{PROG} = 1.1K	● ●	60 120	70 130	80 140	mA mA
V _{PROG}	PROG pin voltage	R _{PROG} = 1.1K, current mode	●	0.9	1.0	1.1	V
V _{CHRG}	V _{CHRG} Pin output low voltage	I _{CHRG} = 5mA			0.3	0.6	V
V _{STDBY}	V _{STDBY} Pin output low voltage	I _{STDBY} = 5mA			0.3	0.6	V
V _{TEMP-H}	TEMP upper trip threshold				80	82	%V _{CC}
V _{TEMP-L}	TEMP lower trip threshold			43	45		%V _{CC}
ΔV _{RECHRG}	Recharge battery threshold voltage	V _{FLOAT} - V _{RECHRG}		50	80	120	mV
T _{LIM}	Junction Temperature in Constant Temperature Mode				145		°C
R _{ON}	The resistance of power FET "ON" (between V _{CC} and BAT)				650		mΩ
t _{SS}	Soft-start time	I _{BAT} = 0 to I _{BAT} = 1100V/R _{PROG}			20		μs
t _{RECHARGE}	Recharge comparator filter time	V _{BAT} from high to low		0.8	1.8	4	ms
t _{TERM}	Termination comparator filter time	I _{BAT} drops below I _{CHG} /10		0.8	1.8	4	ms
I _{PROG}	PROG pin pull-up current				2.0		μA
V _{ADPT}	V _{CC} Adaptive Start Voltage	R _{prog} = 10K, V _{CC} from high to low R _{prog} = 1.1K, V _{CC} from high to low		4.1 4.2	4.2 4.35	4.4 4.5	V V
I _{VIN}	V _{CC} Reverse leakage current	Input terminal reversed, V _{BAT} = V _{FLOAT}			10	20	uA
I _{BAT}	Battery reverse leakage current	Battery reversed, V _{CC} = 5V			3	5	mA
V _{CE_ON}	CE turn-on voltage	V _{CC} = 5V, CE from low to high		0.65	0.8	0.95	V
V _{CE_OFF}	CE turn-off voltage	V _{CC} = 5V, CE from high to low		0.6	0.75	0.9	V

TYPICAL PERFORMANCE CHARACTERISTICS

PROG Pin Voltage vs Supply Voltage
(in constant current mode)

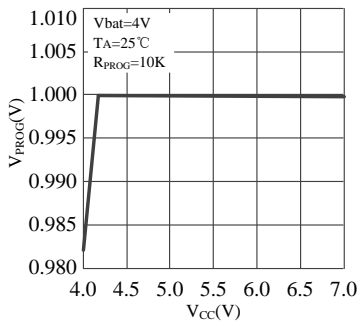

PROG Pin Voltage vs Temperature

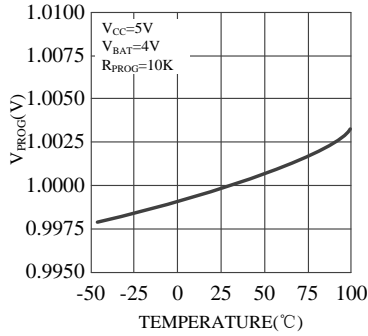

Recharging Current vs PROG Pin Voltage

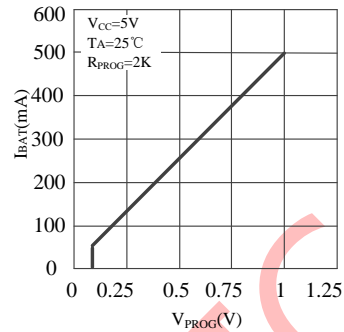

Regulated Output (Float) Voltage vs Charge Current

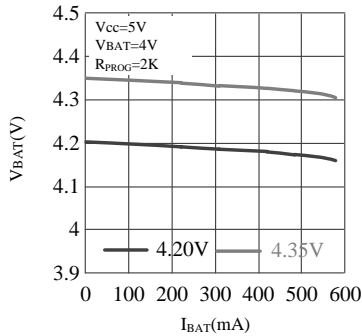

Regulated Output (Float) Voltage vs Temperature

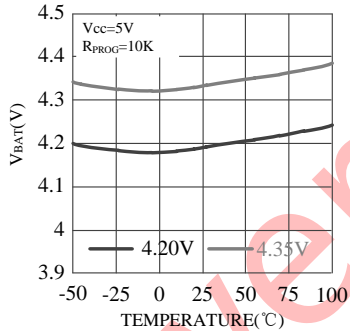

Regulated Output (Float) Voltage vs Supply Voltage

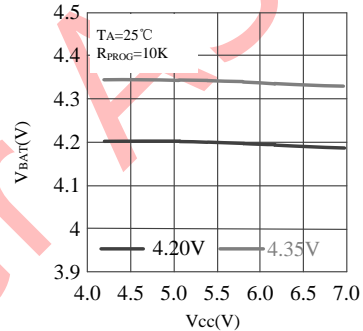

Trickle Charge Threshold Voltage vs Temperature

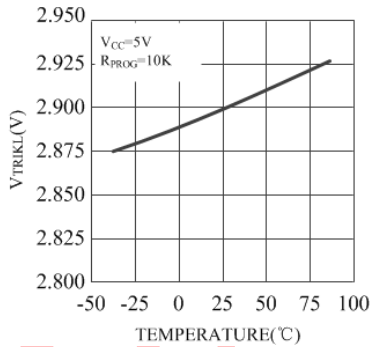

(Charge cut-off voltage is 4.2V)

Recharging Current vs Battery Voltage

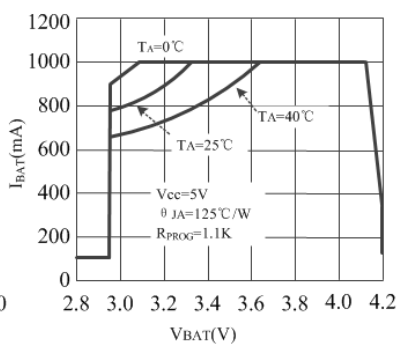

Recharging Current vs Battery Voltage

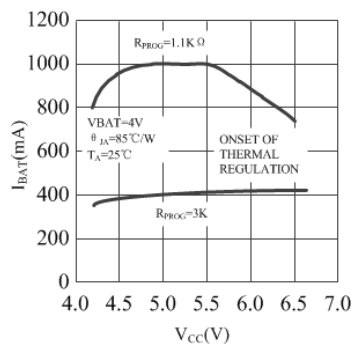

Recharging Current vs Temperature

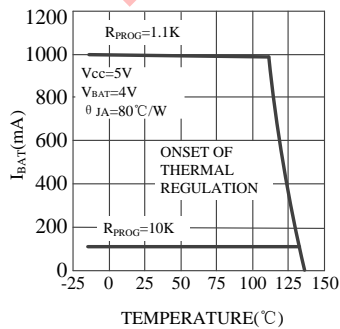

Recharge Threshold Voltage vs Temperature

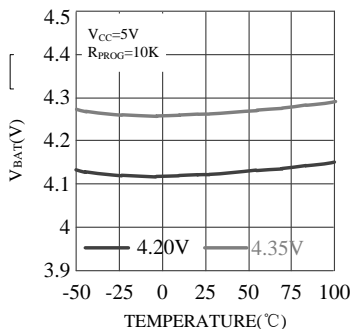

Power FET "ON" Resistance vs Temperature

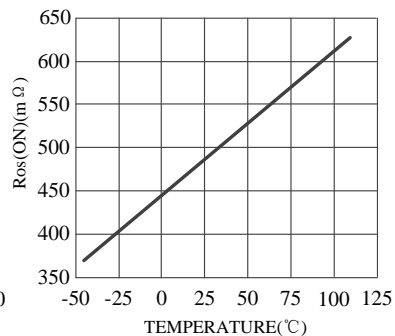

PIN FUNCTIONS

TEMP (Pin1): Temperature Sense Input. Connecting TEMP pin to NTC thermistor's output pin in Lithium-ion battery pack. If TEMP pin's voltage is below 45% or above 80% of supply voltage VIN, this means that battery's temperature is too high or too low, charging is suspended. The temperature sense function can be disabled by grounding the TEMP pin.

PROG (Pin2): Constant Charge Current Programming and Charge Current Monitor. Charge current is programmed by connecting a resistor R_{ISSET} from this pin to GND. During the pre-charging stage, the voltage of this pin is modulated at 0.1V. When in constant-current mode, this pin is regulated to 1V. In all modes during charging, the voltage on this pin can be used to measure the charge current as follows:

$$I_{BAT} = \frac{V_{PROG}}{R_{PROG}} \times 1100$$

GND (Pin3): Ground Terminal

Vcc (Pin4): Positive Input Supply Voltage. Provides power to the charger. When VCC is within 30mV of the BAT pin voltage, the

TP4056X enters shutdown mode dropping BAT pin's current to less than 1μA.

BAT (Pin5): Battery Connection. Connect the positive terminal of the battery to the BAT pin. BAT pin provides charge current to the battery and regulates the final float voltage to 4.2V or 4.35V. BAT pin draws less than 1μA current in chip disable mode or in sleep mode.

\overline{STDBY} (Pin6): Charge Status Open-Drain Output. When battery charge cycle completes, \overline{STDBY} pin is pulled low by an internal switch, otherwise \overline{STDBY} pin is high impedance.

\overline{CHRG} (Pin7): Charge Status Open Drain Output. When the battery is charging, the \overline{CHRG} pin is pulled low by an internal switch, otherwise \overline{CHRG} pin is high impedance.

CE (Pin8): Chip Enable Input. A high input level will make the TP4056X in a normal working state, with a turn-on voltage of about 0.8V; a low input level will make the TP4056X in a state where charging is prohibited. CE pin can be driven by TTL level or CMOS level.

BLOCK DIAGRAM

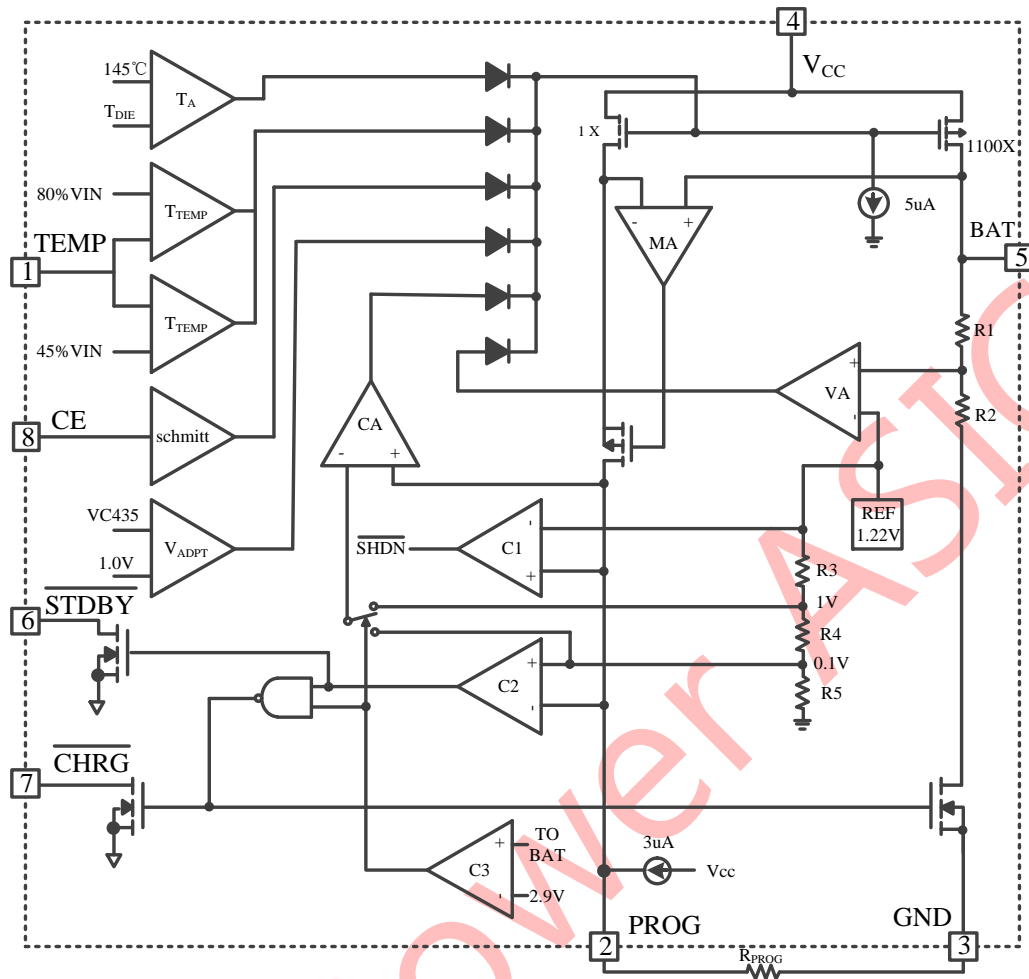

OPERATION (4.2V)

The TP4056X is a complete CC/CV linear charger for single cell lithium-ion batteries. It can deliver up to 1A of charge current with a final float voltage accuracy of $\pm 1\%$. The TP4056X includes an internal PMOS architecture and thermal regulation circuitry. No blocking diode or external current sense resistor is required. TP4056X includes two charge status open-drain pins: charge status indicator \overline{CHRG} and battery failure status output \overline{STDBY} . The internal thermal regulation circuit reduces the programmed charge current if the die temperature attempts to rise above a preset value of approximately 145 °C. This feature protects the TP4056X from excessive temperature, and allows the user to push the limits of the power handling capability of a given circuit board without risk of damaging the TP4056X. Another benefit of adopting thermal regulation is that charge current can be set according to typical, not worst-case, ambient temperature for a given application with the assurance that the charger will automatically

reduce the current in worst-case conditions.

The charge cycle begins when the voltage at the V_{CC} pin rises above the UVLO threshold level, a program resistor is connected from the PROG pin to ground, and the CE pin is pulled above the chip enable threshold. The \overline{CHRG} pin outputs a logic low to indicate that the charge cycle is on going. When the battery voltage is below 3V, the charger enters trickle charge mode to bring the battery voltage up to a safe level for charging. When voltage on the BAT pin rises above 3V, the charger goes into the fast charge CC mode. In CC mode, the charge current is set by R_{PROG} . When the battery approaches the final float voltage of 4.2V, the charge current begins to decrease as the TP4056X enters the CV mode. When the charge current drops to 1/10th of the programmed value, the charge cycle terminates, and \overline{CHRG} pin becomes high impedance while \overline{STDBY} pin is pulled low.

The charge cycle can also be automatically

restarted if the BAT pin voltage falls below the recharge threshold. The on-chip reference voltage, error amplifier and the resistor divider network provide regulation voltage with 1% accuracy, which can meet the requirement of lithium-ion and lithium polymer batteries. When the input voltage is not present, or input voltage is below V_{BAT}, the charger enters a sleep mode, dropping battery drain current to less than

1μA. This greatly reduces the current drain on the battery and increases the standby time. The charger can be shut down by forcing the CE pin to GND.

Programming Charge Current

The charge current is programmed using a single resistor from the PROG pin to ground. The program resistor and the charge current are calculated using the following equations.

$$R_{PROG} = \frac{1100}{I_{BAT}}$$

In applications, one can refer to the following chart showing the relation between R_{PROG} and charge current:

R _{PROG} (k)	I _{BAT} (mA)
30	50
20	70
10	130
5	250
4	300
3	400
2	580
1.6	690
1.4	780
1.2	900
1.1	1000

Charge Termination

A charge cycle terminates when the charge current falls to 1/10th the programmed value after the final float voltage is reached. This condition is detected by using an internal filtered comparator to monitor the PROG pin. When the PROG pin voltage falls below 100mV for longer than t_{TEMP} (typically 1.8ms), charging is terminated. The charge current is latched off and the TP4056X enters standby mode, where the input supply current drops to 70μA.

(Note: C/10 termination is disabled in trickle charging and thermal limiting modes).

When charging, transient loads on the BAT pin can cause the PROG pin to fall below 100mV for short periods of time before the DC charge current has dropped to 1/10th the programmed value. The 1.8ms filter time (t_{TEMP}) on the termination comparator ensures that transient loads of this nature do not result in premature

charge cycle termination. Once the average charge current drops below 1/10th the programmed value, the TP4056X terminates the charge cycle and ceases to provide any current through the BAT pin. In this state all loads on the BAT pin must be supplied by the battery.

The TP4056X constantly monitors the BAT pin voltage in standby mode. If this voltage drops below the 4.12V recharge threshold (V_{RECHRG}), another charge cycle begins and charge current is once again supplied to the battery. Figure 1 shows the state diagram of a typical charge cycle.

Charge status indicator

TP4056X has two open-drain status indicator: \overline{CHRG} and \overline{STDBY} . \overline{CHRG} is pull-down when the TP4056X is in a charge cycle, and \overline{CHRG} becomes high impedance for other states. Both \overline{CHRG} and \overline{STDBY} will be high impedance when the battery is operating out of the normal temperature.

When TEMP pin is connected, and battery is not connected to charger: both red LED and green LED are OFF to indicate a failure mode. When TEMP is grounded, the battery temperature sense function is disabled. If battery is not connected to charger, \overline{CHRG} pin outputs a PWM level to indicate no battery failure mode. If BAT pin connects to a 10 μ F capacitor, the frequency of \overline{CHRG} flicking will be with T=1-4s.

If not using a status indicator, the pins should be connected to GND.

Charger's Status	Red LED \overline{CHRG}	Green LED \overline{STDBY}
Charging	ON	OFF
Charging Completes	OFF	ON
Under-voltage, battery's temperature is too high or too low, or not connect to battery (TEMP pin in use)	OFF	OFF
BAT pin is connected to 10uF capacitor, and not connect to battery (TEMP connects to GND)	Green LED ON, Red LED flickering with T=1-4s	

Thermal limiting

An internal thermal feedback loop reduces the programmed charge current if the die temperature attempts to rise above a preset value of approximately 140 °C, and current will be

reduced to zero if die temperature reaches beyond 150 °C. This feature protects the TP4056X from excessive temperature and allows the user to push the limits of the power handling capability of a given circuit board without risk of damaging the TP4056X. The charge current can be set according to typical (not worst-case) ambient temperature with the assurance that the charger will automatically reduce the current in worst-case conditions.

To prevent the damage caused by the very high or very low temperature done to the battery pack, the TP4056X continuously senses battery pack temperature by measuring the voltage at TEMP pin determined by the internal voltage divider circuit and the battery's internal NTC thermistor as shown in Figure 1.

The TP4056X compares the voltage at TEMP pin (V_{TEMP}) against its internal V_{TEMP_L} and V_{TEMP_H} thresholds to determine if charging is allowed. V_{TEMP_L} is fixed at $(45\% \times V_{CC})$, while V_{TEMP_H} is fixed at $(80\% \times V_{CC})$. If $V_{TEMP} < V_{TEMP_L}$ or $V_{TEMP} > V_{TEMP_H}$, it indicates that the battery temperature is too high or too low and the charge cycle is suspended. When V_{TEMP} is in between V_{TEMP_L} and V_{TEMP_H} , charging cycle resumes. The battery temperature sense function can be disabled by connecting TEMP pin to GND.

Selecting R1 and R2

The values of R1 and R2 in the application circuit can be determined according to the assumed temperature monitor range and thermistor's values. See following example as a reference:

Assume temperature monitor range is $T_L \sim T_H$, ($T_L < T_H$); the thermistor in battery has negative temperature coefficient (NTC). R_{TL} is thermistor's resistance at T_L , R_{TH} is the resistance at T_H , so $R_{TL} > R_{TH}$.

Then at temperature T_L , the voltage at TEMP pin is:

$$V_{TEMP_L} = \frac{R2 \parallel R_{TL}}{R1 + R2 \parallel R_{TL}} \times V_{IN}$$

At temperature T_H , the voltage at TEMP pin is: .

$$V_{TEMP_H} = \frac{R2 \parallel R_{TH}}{R1 + R2 \parallel R_{TH}} \times V_{IN}$$

We know $V_{TEMP_L} = V_{HIGH} = K2 \times V_{CC}$
($K2=0.8$) ; $V_{TEMP_H} = V_{LOW} = K1 \times V_{CC}$
($K1=0.45$)

Then we can have :

$$R1 = \frac{R_{TL} R_{TH} (K_2 - K_1)}{(R_{TL} - R_{TH}) K_1 K_2}$$

$$R2 = \frac{R_{TL} R_{TH} (K_2 - K_1)}{R_{TL} (K_1 - K_1 K_2) - R_{TH} (K_2 - K_1 K_2)}$$

Likewise, for positive temperature coefficient thermistor in battery, we have $R_{TH} > R_{TL}$ and we can calculate:

$$R1 = \frac{R_{TL} R_{TH} (K_2 - K_1)}{(R_{TH} - R_{TL}) K_1 K_2}$$

$$R2 = \frac{R_{TL} R_{TH} (K_2 - K_1)}{R_{TH} (K_1 - K_1 K_2) - R_{TL} (K_2 - K_1 K_2)}$$

We can conclude that temperature monitor range is independent of power supply voltage V_{CC} and it only depends on R1, R2, R_{TL} and R_{TH} . The values of R_{TH} and R_{TL} can be found in the related battery handbook or deduced from testing data. In actual application, if considering only one terminal temperature (normally protecting from overheating), there is no need to use R2.

Under Voltage lockout (UVLO)

An internal under voltage lockout circuit monitors the input voltage and keeps the charger in shutdown mode until V_{CC} rises above the under-voltage lockout threshold. If the UVLO comparator is tripped, the charger will not come out of shutdown mode until V_{CC} rises 100mV above the battery voltage.

Manual Shutdown

At any time in the charge cycle, the TP4056X can be put into shutdown mode by pulling CE pin to GND, or removing R_{PROG} ($PROG$ pin is float). This reduces the battery drain current to less than $2\mu A$ and the supply current to less than $55\mu A$. To restart the charge cycle, pullup CE pin or connect a programming resistor.

If TP4056X is in the under-voltage Lockout mode, both \overline{CHRG} and \overline{STDBY} become high impedance, meaning V_{CC} is not at least 100mV above BAT pin voltage, or V_{CC} is too low.

Automatic Recharge

Once the charge cycle is terminated, the TP4056X continues to monitor the voltage on BAT pin using a termination comparator with 1.8ms filter time ($t_{RECHARGE}$). If battery voltage drops below the 4.05V recharge threshold (approximately 80% to 90% of battery capacity), another charge cycle begins. This

ensures the battery is kept at, or near, a fully charged condition to avoid the requirement of periodic charge cycle initiations. During recharge cycles, \overline{CHRG} pin enters a pulled down state.

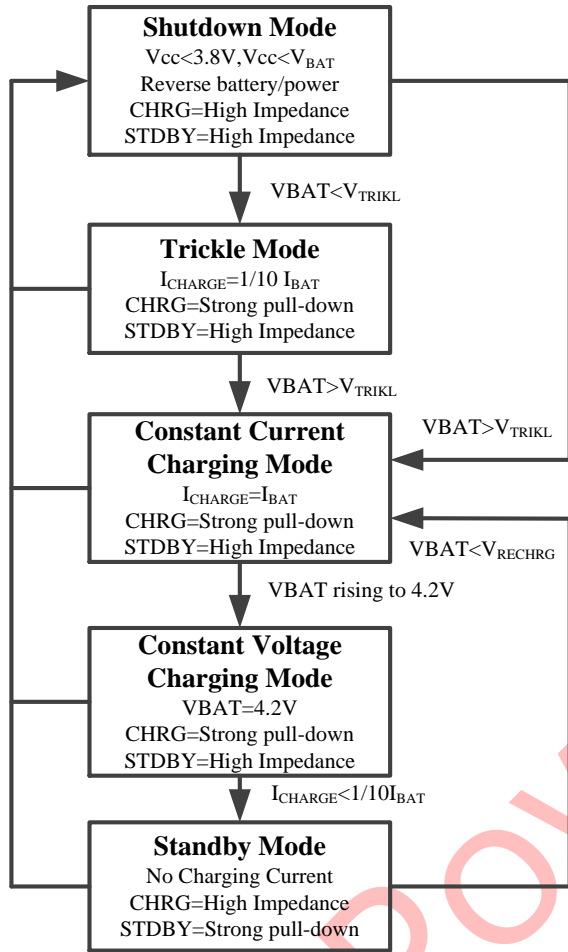

Fig.1 State diagram of a typical charge cycle

Stability Considerations

In constant-current mode, the PROG pin is in the feedback loop, not the battery. The constant-current mode stability is affected by the impedance at the PROG pin. Additional capacitance on this node reduces the maximum allowed program resistor. If the PROG pin is loaded with a capacitance, C_{PROG} , the following equation can be used to calculate the maximum resistance value for R_{PROG} :

$$R_{PROG} \leq \frac{1}{2\pi \cdot 10^5 \cdot C_{PROG}}$$

Typically, average rather than instantaneous charge current may be of more interest to the user. For example, if a switching power supply operating in low current mode is connected in parallel with the battery, the average current being pulled out of the BAT pin is typically of

more interest than the instantaneous current pulses. In such a case, a simple RC filter can be used on the PROG pin to measure the average battery current, as shown in Figure 2. A 10k resistor has been added between the PROG pin and the filter capacitor to ensure stability.

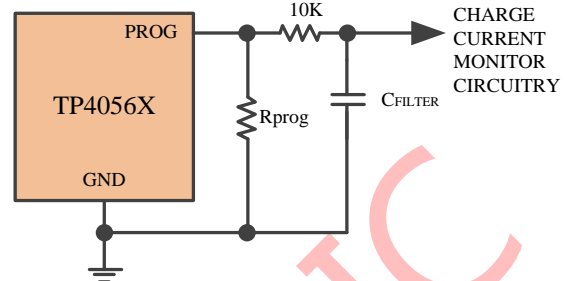

Fig.2 Isolating Capacitive Load on PROG Pin and Filtering

Power Dissipation

The conditions that cause the TP4056X to reduce charge current through thermal feedback can be approximated by considering the power dissipated in the IC. Nearly all of this power dissipation is generated by the internal MOSFET—this is calculated to be approximately:

$$P_D = (V_{CC} - V_{BAT}) \cdot I_{BAT}$$

where P_D is the power dissipated, V_{CC} is the input supply voltage, V_{BAT} is the battery voltage and I_{BAT} is the charge current. The approximate ambient temperature at which the thermal feedback begins to protect the IC is:

$$T_A = 145^\circ C - P_D \theta_{JA}$$

$$T_A = 145^\circ C - (V_{CC} - V_{BAT}) \cdot I_{BAT} \cdot \theta_{JA}$$

It is important to remember that TP4056X applications do not need to be designed for worst-case thermal conditions since the IC will automatically reduce power dissipation when the junction temperature reaches approximately 145°C.

Thermal Considerations

Because of the small size of the thin ESOP8 package, it is important to use a good thermal PC board layout to maximize the available charge current. The PC board copper is the heat sink. The footprint of the copper pads should be as wide as possible to spread and dissipate the heat to the surrounding ambient. Other heat sources on the board, not related to the charger, must also be considered when designing a PC board layout because they will have an impact on overall temperature rise and the maximum charge

current.

Increasing Charge Current with Thermal Mode

Furthermore, lowering voltage across MOSFET can effectively reduce power dissipation of the IC during thermal regulation. An option is to dissipate some portion of the heat through an external component (resistor or a diode).

An example: A TP4056X operating from a 5V supply is programmed to supply 800mA full-scale current to a discharged Li-Ion battery with a voltage of 3.75V. Assuming θ_{JA} is $125^{\circ}\text{C}/\text{W}$, at 25°C the charge current is approximately:

$$I_{BAT} = \frac{145^{\circ}\text{C} - 25^{\circ}\text{C}}{(5\text{V} - 3.75\text{V}) \cdot 125^{\circ}\text{C}/\text{W}} = 768\text{mA}$$

Power dissipation can be reduced by lowering voltage across the resistor that's in series with the 5V supply, increasing charge current:

$$I_{BAT} = \frac{145^{\circ}\text{C} - 25^{\circ}\text{C}}{(V_S - I_{BAT}R_{CC} - V_{BAT}) \cdot \theta_{JA}}$$

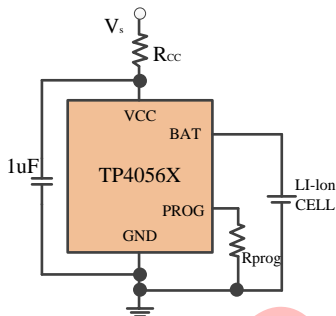

Fig.3 Circuit Example to Increase Charging Current

$$I_{BAT} = \frac{(V_S - V_{BAT}) - \sqrt{(V_S - V_{BAT})^2 - \frac{4R_{CC}(145^{\circ}\text{C} - T_A)}{\theta_{JA}}}}{2R_{CC}}$$

$I_{BAT} = 948\text{mA}$, which shows such a circuit can supply 800mA full-scale charge current at a higher temperature.

Although this application can supply more charge current to save charging time, if Vcc drops low enough to make TP4056X at a low dropout mode, charging time may increase. Rcc needs to be carefully picked and dropout should be avoided to make this technique fully effective.

Vcc Bypass Capacitor

Many types of capacitors can be used for input bypassing, however, caution must be exercised when using multilayer ceramic capacitors. Because of the self-resonant and high Q characteristics of some types of ceramic capacitors, high voltage transients can be

generated under some start-up conditions, such as connecting the charger input to a live power source. High quality ceramic or tantalum capacitors are recommended.

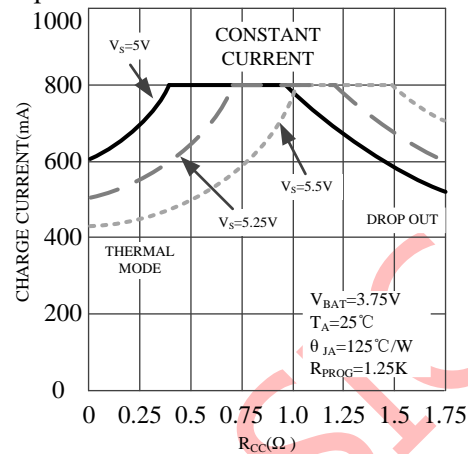

Fig.4 Charging Current vs Rcc

Charge Current Soft-Start

TP4056X includes a soft-start circuit to reduce the inrush current in the beginning of the charge cycle. When restarting a new charge cycle, the charging current ramps up from 0 to the full charging current over a period of $20\mu\text{s}$, which can effectively minimize the transient current load on power supply during startup.

Reverse Polarity Input Voltage Protection

In some applications, protection from reverse polarity

voltage on VCC is required, and a series blocking diode can be used with high supply voltage while a P-channel MOSFET can be used when voltage drop needs to be kept low.

USB and Wall Adapter Power

The TP4056X supports charging from both a wall adapter and a USB port. Figure 5 shows an example of how to combine a wall adapter and USB power inputs.

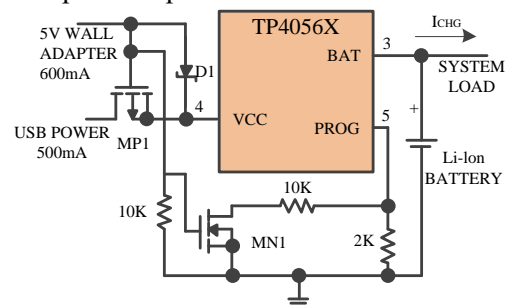

Fig.5 USB and Wall Adaptor Power

Power Adaptation

When $R_{prog} \geq 10K$, the adaptive circuit starts when VCC is powered off to 4.35V; when $R_{prog} < 10K$, when VCC is powered off and drops to 4.2V, the adaptive circuit starts; automatically reduces the output current until VCC no longer decreases, the function can use the high-current charging system as the power source with USB or low-power power adapter, solar battery, and avoid power reset or restart.

Battery Reverse Polarity Protection

TP4056X has lithium battery reverse connection protection function. When the positive and negative electrodes of the battery are reversely connected to the current output BAT pin of the TP4056X, the TP4056X will stop and display the fault status without charging current. The charging indicator pin is in a high resistance state, RLED is off, and GLED is slightly on. At this time, the leakage current of the reversely connected battery is less than 5mA. Connect the reversed battery correctly and the TP4056X will automatically start the charging cycle.

After the reverse connection of TP4056X, when the battery is removed, since the capacitor potential of the BAT pin at the output end of the TP4056X is still negative, the TP4056X indicator light will not light up normally immediately, and the charging can be automatically activated only when the battery is correctly connected. Or wait for a long time for the negative potential of the BAT terminal to discharge, and the BAT terminal potential is greater than zero volts, and the TP4056X will display the normal no-battery indicator light state.

In the case of reverse connection, the power supply voltage should be around the standard voltage of 5V and should not exceed 6.5V. When the power supply voltage is too high, the voltage difference of the chip will exceed the limit withstand voltage when the battery voltage is reversed.

VIN Input Terminal Reverse Connection Protection Function

TP4056X has the function of power reverse connection protection. When the positive and negative poles of VIN are reversely connected to the VCC pin of TP4056X, TP4056X will stop and display the fault status without charging

current. The charging indicator pin is in a high-impedance state, the LED light is off, and the leakage current of the reversely connected power supply is less than 10uA (excluding CE terminal high-level leakage). Correctly connect the reversed power supply to the TP4056X to automatically start the charging cycle. **When the CE end is not in use, a resistor needs to be connected to the VIN, and the R_{CE} resistance value is around 10K~100K.**

Precautions For Use

1. TP4056X is packaged in ESOP8. The bottom heat sink should be well welded to the PCB in use. The bottom heat dissipation area needs to add through holes, and it is better to have a large area of copper foil for heat dissipation. Multi-layer PCB with sufficient vias has a good effect on heat dissipation. Poor heat dissipation may cause the charging current to be reduced by temperature protection. Adding appropriate vias to the heat dissipation part on the back of the ESOP8 also facilitates manual soldering (you can pour solder from the backside vias to reliably solder the heat dissipation surface).
2. TP4056X is used in high-current charging (above 700mA). In order to shorten the charging time, it is necessary to increase the heat dissipation resistance, and the resistance value ranges from 0.2 to 0.5Ω. The customer selects the appropriate resistor size according to the usage.
3. In order to ensure reliable use in various situations and prevent chip damage caused by peak and glitch voltages, it is recommended that 10uF capacitors be connected to the VIN terminal and BAT terminal respectively in TP4056X applications, and a 0.1uF ceramic capacitor can be connected if possible. All capacitor positions are preferably close to the chip pins, and should not be too far away.
4. If the battery temperature detection input terminal is used normally, when it is not grounded, it is necessary to connect a 1uF capacitor to the ground and close to the chip pin to increase the reliability of the chip.
5. In the TP4056X test, the BAT port should be directly connected to the battery, and the ammeter cannot be connected in series. The ammeter can be connected to the Vcc terminal.

OTHER TYPICAL APPLICATIONS

1. With temperature monitoring and charging status indicators.

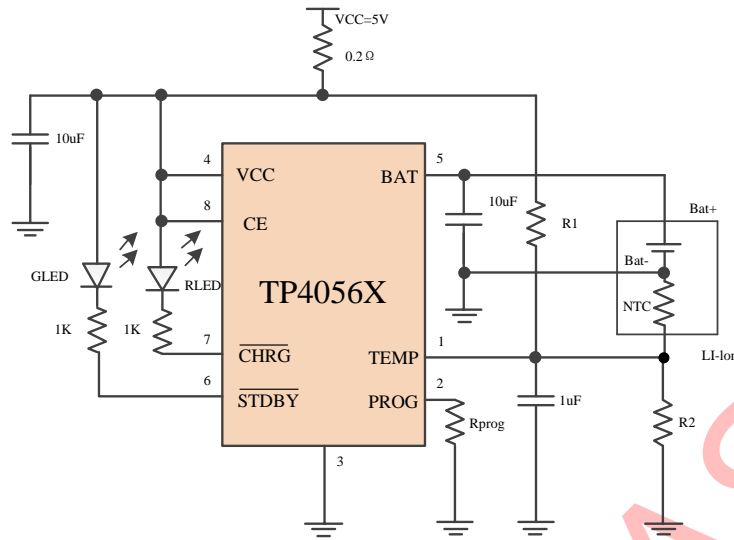

2. With charging status indicator but no battery temperature monitoring (Left)

3. With neither charging status indicator nor battery temperature monitoring (Right)

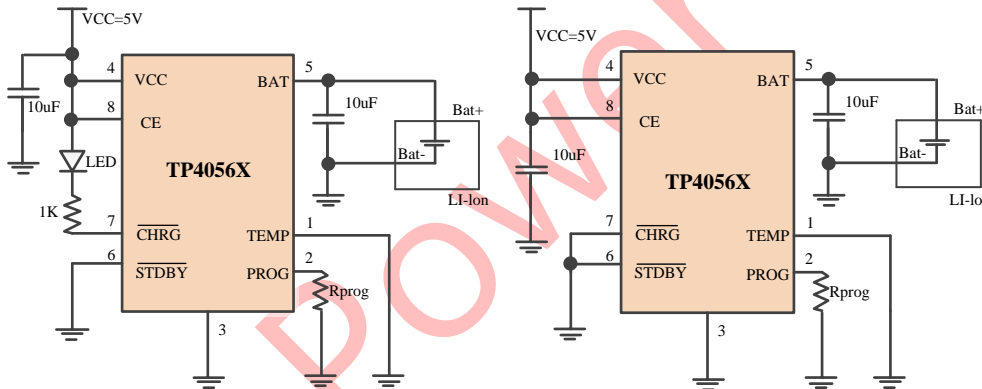

4. Applications for both USB and Wall adaptor charging (Left)

5. Red LED for charging, green LED for charging completes. External resistance for heat dissipation. (Right)

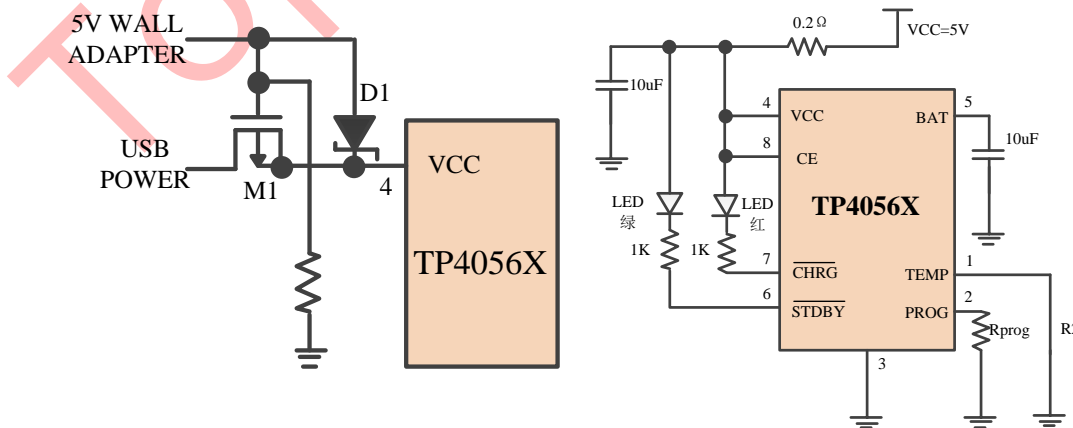

DEMO Board Instructions

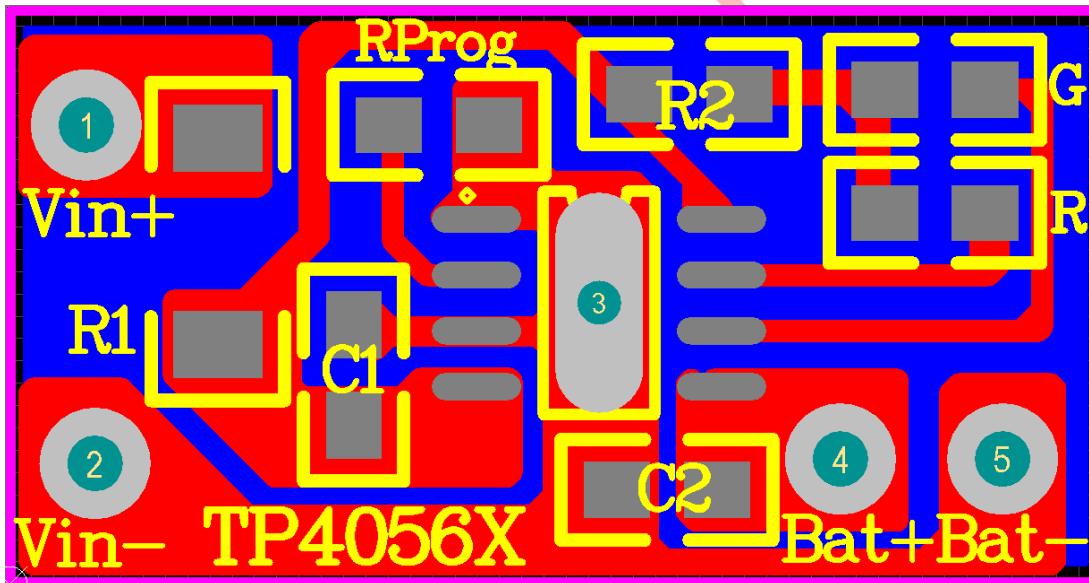
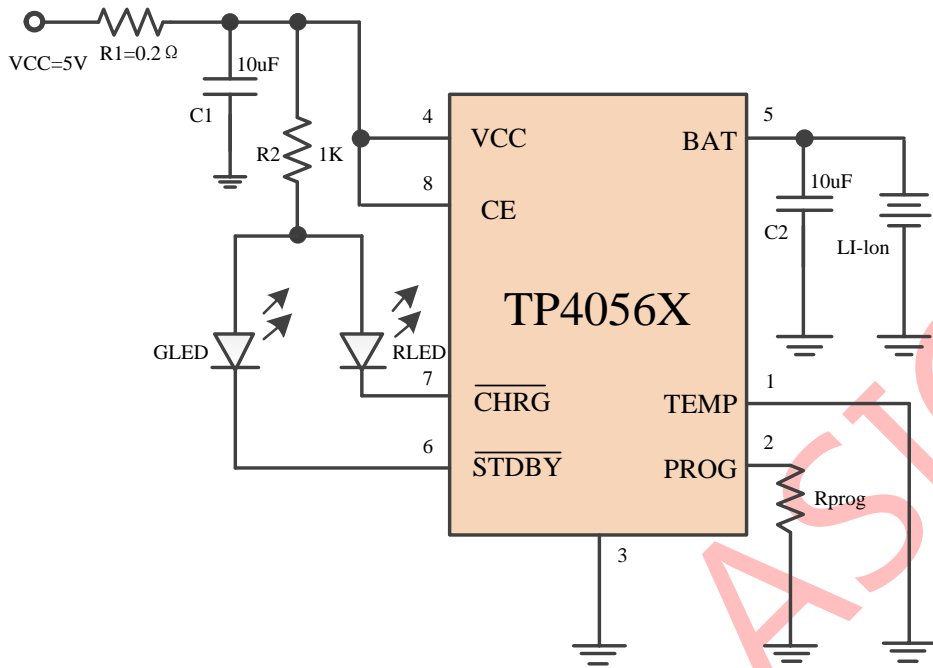

PACKAGE DESCRIPTION: ESOP8

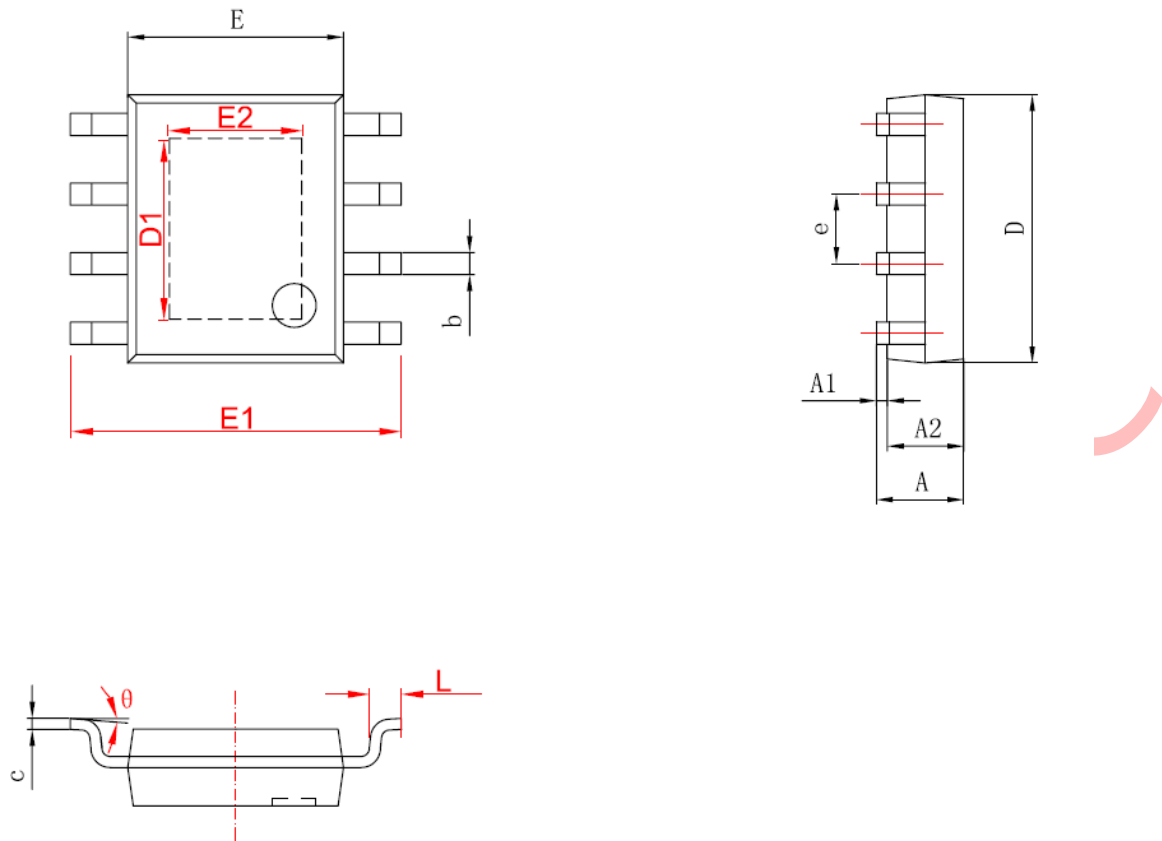

字符	Dimensions In Millimeters		Dimensions In Inches	
	Min	Max	Min	Max
A	1.350	1.750	0.053	0.069
A1	0.050	0.150	0.004	0.010
A2	1.350	1.550	0.053	0.061
b	0.330	0.510	0.013	0.020
c	0.170	0.250	0.006	0.010
D	4.700	5.100	0.185	0.200
D1	3.202	3.402	0.126	0.134
E	3.800	4.000	0.150	0.157
E1	5.800	6.200	0.228	0.244
E2	2.313	2.513	0.091	0.099
e	1.270 (BSC)		0.050 (BSC)	
L	0.400	1.270	0.016	0.050
θ	0°		8°	