

南京拓品微电子有限公司

NanJing Top Power ASIC Corp.

数据手册

DATASHEET

TP4065

(3mA-600mA Linear
Li-Ion Battery Charger)

DESCRIPTION

The TP4065 is a complete linear charger for single cell lithium-ion batteries. The world's first create chip with reverse battery protection and power supply reverse connect protection. The charge current can range from 3mA to 600mA , and it includes trickle, constant-current and constant-voltage. Its SOT23-5 package and low external component count make the TP4065 ideally suited for portable applications. Furthermore, the TP4065 can work within USB and wall adapter.

Thermal feedback regulates the charge current to limit the die temperature during high power operation or high ambient temperature. The charge voltage can be divided 4.2 V, and the charge current can be programmed externally with a single resistor. The TP4065 automatically terminates the charge cycle when the charge current drops to 1/10th the programmed value after the final float voltage reaching.

When the input supply (wall adapter or USB supply) is removed, the TP4065 automatically enters a low current state, dropping the battery drain current to less than 1uA. The TP4065 can be put into shut down mode, reducing the supply current to 75uA. Other features include under voltage lockout, automatic recharge and one status pins to indicate charge termination.

FEATURES

- Programmable Charge Current range from 3mA to 600mA
- VCC input reverse connect protection
- Lithium-ion batteries Reverse battery protection
- Maximize Charge Rate Without Risk of Overheating
- For Single Cell titanic acid Lithium-Ion Batteries
- Trickle, constant-current and constant-voltage control
- Charges Single Cell Li-Ion Batteries Directly from USB Port
- Preset Charge Voltage with 1% Accuracy
- Highest input can be up to 8V
- Automatic Recharge
- One Charge Status Output Pins
- C/10 Charge Termination
- 75uA Supply Current in Shutdown
- Available in 5-Lead SOT-23 Package

APPLICATIONS

- Miniature lithium battery
- Cellular phone、PAD、MP3 player

TYPICAL APPLICATION

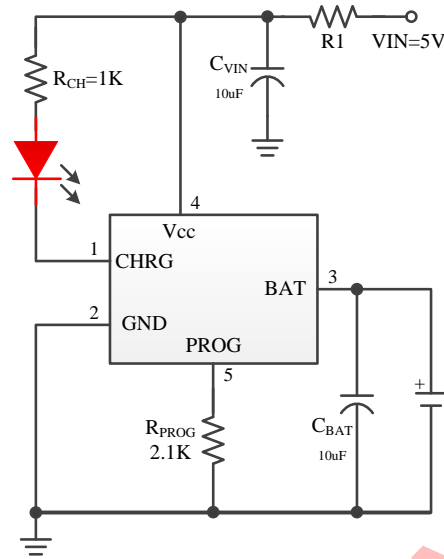
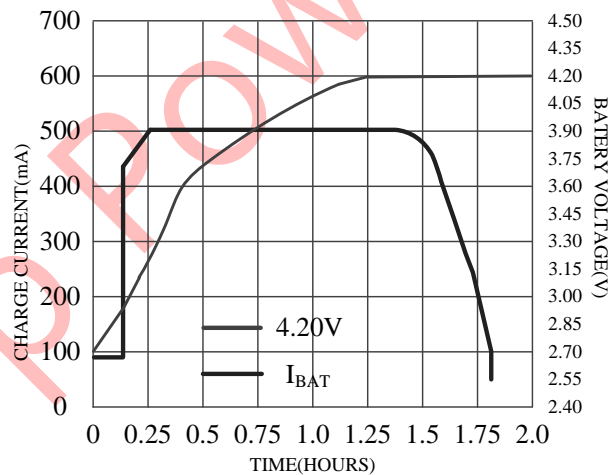

Figure 1 500mA Single Cell Li-Ion Charger

Note: Proposed R1 dissipation resistor, it can get a larger charge current, and also improve the reliability of the machine. Resistance is selected according to the actual situation (0 ~ 0.6 Ω).

Complete Charge Cycle (500mAh Battery)



ABSOLUTE MAXIMUM RATINGS

- VCC: -6.5V~8V
- PROG: -0.3V~VCC+0.3V
- BAT: -4.2V~7V
- CHRG: -0.3V~10V
- BAT Pin Current: 700mA
- PROG Pin Current: 2mA
- Maximum Junction Temperature:

150°C

- Operating Ambient Temperature Range: -40°C~85°C
- Storage Temperature Range: -65°C~125°C
- Lead Temperature(Soldering, 10sec): 260°C

PACKAGE DESCRIPTION

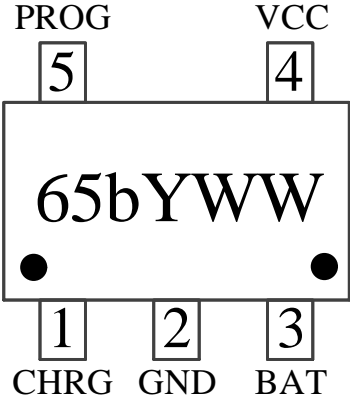
	<p>ORDER PART NUMBER</p>
	<p>TP4065-4.2V-SOT235</p>
	<p>PART MARKING</p>
	<p>65bYWW→4.2V</p>

Pin Description

CHRG (Pin1): Open Drain Charge Status Output When the battery is being charged, the CHRG pin is pulled low by the internal switch to indicate that charging is in progress; otherwise, the CHRG pin is in a high-impedance state.

GND (Pin2): Ground Terminal

BAT (Pin3): Battery Connection Pin
This pin provides the charging current to the battery and adjusts the final float voltage to 4.2V. An accurate internal resistor divider for this pin sets the float voltage, which in the shutdown mode, the internal resistor divider is disconnected.

Vcc (Pin4): Positive Input Supply Voltage

This pin supplies power to the internal circuit. Vcc varies from 4V to 8V and should be bypassed by at least one 10 μ F capacitor. When Vcc drops to within 90mV of the BAT pin voltage, TP4065 enters low power sleep mode, dropping

BAT pin's current to less than 1 μ A.

PROG (Pin5): Charge current setting, charge current monitoring and shutdown pin

A precision of 1% of the resistance R_{PROG} between the pin and ground to set the charge current. When in constant charge current mode, the voltage of the pin is maintained at 1V.

The PROG pin can also be used to turn off the charger. Setting the resistor to ground, a 0.2 μ A current internally pulls the PROG pin high. When the pin voltage reaches the shutdown threshold voltage 2.7V, the charger enters shutdown mode, charging is stopped and the input supply current to 75 μ A. Re-connecting R_{PROG} to ground will cause the charger to return to normal operation.

ELECTRICAL CHARACTERISTICS

The ● denotes specifications which apply over the full operating temperature range, otherwise specifications are at TA=25°C, VCC=5V, unless otherwise noted.

SYMBOL	PARAMETER	CONDITIONS		MIN	TYP	MAX	UNITS
VCC	Input Supply Voltage		●	4.35	5	8.0	V
ICC	Input Supply Current	Charge Mode, R _{PROG} = 10K	●		75	130	μA
		Standby Mode (Charge Terminated)	●		75	130	μA
		Shutdown Mode (R _{PROG} Not Connected, VCC < V _{BAT} , or VCC < V _{UV})	●		75	130	μA
V _{FLOAT}	Regulated Output (Float) Voltage	0 °C ≤ TA ≤ 85 °C, I _{BAT} =25mA, R _{PROG} =10K		4.158	4.2	4.242	V
I _{BAT} (Take the cut-off voltage 4.2V for example)	BAT Pin Current (Except that V _{BAT} =4.0V)	R _{PROG} = 300K, Current Mode	●	2	3	4	mA
		R _{PROG} = 10K, Current Mode	●	76	90	104	mA
		R _{PROG} = 2.1K, Current Mode	●	425	500	575	mA
		Standby Mode, V _{BAT} = 4.3V			-1.5	-6	μA
		Shutdown Mode (R _{PROG} Not Connected)			±1	±2	μA
		Sleep Mode, VCC = 0V			-1	-2	μA
I _{TRIKL}	Trickle Charge Current	V _{BAT} <V _{TRIKL} , R _{PROG} =10K	●	10	15	20	mA
V _{UV}	VCC Undervoltage Lockout Threshold	From VCC Low to High	●	3.6	3.8	4	V
I _{TERM}	C/10 Termination Current Threshold	R _{PROG} =10K	●	7	8	10	mA
		R _{PROG} =2.1K	●	40	50	55	mA
V _{PROG}	PROG Pin Voltage	R _{PROG} =10K, Current Mode	●	0.9	0.95	1	V
V _{CHRG}	CHRG Pin Output versr Low Voltage	I _{CHRG} =3mA			0.7	1	V
I _{VIN}	VIN reverse leakage current	VIN reverse, V _{BAT} =4.2V		0		20	μA
I _{BAT}	Battery reverse leakage current	Battery reverse, VIN = 5V		1	2.5	5	mA

OPERATION

TP4065 is a single lithium ion battery charger using constant current/constant voltage algorithm. It is capable of providing 3 mA-600mA charging current (with the help of a thermally designed PCB layout) and an internal P-channel power MOSFET and thermal regulation circuit. No isolation diodes or external current detection resistors; Thus, the basic charger circuit requires only two external components. Not only that, the TP4065 can also get a working power supply from a USB power supply.

Normal charging cycle

A charging cycle begins when the Vcc pin voltage rises above the UVLO threshold level and a 1% precision setting resistor is connected between the PROG pin and ground or when a battery is connected to the charger output. If the BAT pin level is lower than the trickle charging threshold voltage, then the charger enters the trickle charging mode. In this mode, the TP4065 provides about 15% of the set charging current in order to raise the current voltage to a safe level for full current charging.

When the BAT pin voltage rises above the trickle charging threshold voltage, the charger enters the constant current mode, which provides a constant charging current to the battery. When the BAT pin voltage reaches the final floating charging voltage, TP4065 enters the constant voltage mode and the charging current begins to decrease. When the charging current drops to 1/10 of the set value, the charging cycle ends.

Charging current setting

The charging current is set by a resistor connected between the PROG pin and the ground. The setting resistor and charging current are calculated by the following

formula, and the resistance value of the resistor is determined according to the required charging current:

$$\text{Formula one: } R_{PROG} = \frac{1050}{I_{BAT}} \quad (I_{BAT} > 0.2A)$$

$$\text{Formula two: } R_{PROG} = \frac{950}{I_{BAT}} \quad (0.1A <$$

$I_{BAT} \leq 0.2A)$

$$\text{Formula three: } R_{PROG} = \frac{900}{I_{BAT}} \quad (0.05A <$$

$I_{BAT} \leq 0.1A)$

NOTES: For the Settings below 50mA, refer to the resistance table below.

In applications larger than 0.4A, the chip heat is relatively large, and the temperature protection will reduce the charging current, and the test current in different environments is not completely consistent with the theoretical value calculated by the formula. In customer applications, an R_{PROG} of an appropriate size can be selected as required (**for reference only**) .

R _{PROG} (K)	I _{BAT} (mA)
200	3
100	5
33	22
21.5	35
16.5	50
10	90
2.5	400
2.1	500
1.8	600

Charge termination

The charging cycle is terminated when the charging current drops to 1/10 of the set value after reaching the final floating charging voltage. This condition is detected by using an internal filter comparator to monitor the PROG pins. Charging is terminated when the PROG pin voltage drops below 100mV for

more than t_{TERM} . The charging current is locked off, and the TP4065 enters the standby mode. At this time, the input power current drops to $75\mu A$. (Note: C/10 terminates in trickle charging and heat limiting modes).

When charging, the transient load on the BAT pin will cause the PROG pin voltage to drop below 100mV temporarily between 1/10 of the DC charging current to the set value. The 20ms filter time (t_{TERM}) on the termination comparator ensures that transient loads of this nature do not cause premature termination of the charging cycle. Once the average charging current drops below 1/10 of the set value, the TP4065 terminates the charging cycle and stops providing any current through the BAT pin. In this state, all loads on the BAT pins must be powered by batteries.

In standby mode, TP4065 continuously monitors the BAT pin voltage. If the pin voltage drops below the recharging voltage threshold (V_{RECHRG}), another charging cycle starts and supplies current to the battery again. When manual restart of the charging cycle is performed in standby mode, either the charger must be cancelled and then the input voltage applied, or the charger must be turned off and restarted using the PROG pin. Figure 4 shows the state diagram of a typical charging cycle.

Battery reverse connection protection function

TP4065 has the protection function of lithium battery reverse connection. When the positive and negative electrodes of the battery are connected to the current output BAT pin of TP4065, TP4065 will stop and show the fault state without charging current. The two charging indicator pins are in a high resistance state, and the LED is bright. At this time, the leakage current of the reverse battery is less than 5mA. When the reverse battery is connected correctly, TP4065 will start

charging cycle automatically.

After the reverse connection of TP4065, when the battery is removed, because the capacitance potential of the BAT pin at the output end of TP4065 is still negative, the TP4065 indicator light will not immediately normal light, only correctly connected to the battery can automatically activate charging. Or after waiting for a long time, the negative potential of the BAT terminal will emit light. If the potential of the BAT terminal is greater than zero VOLT, TP4065 will display the normal state of no battery indicator.

In the case of reverse connection, the power supply voltage should be around 5V standard voltage, should not exceed 5.5V. When the power supply voltage is too high, the voltage difference of the chip will exceed the limit voltage.

VIN input reverse connection protection function

TP4065 has the protection function of power reverse connection. When the positive and negative poles of VIN are inversely connected to TP4065 VCC pins, TP4065 will stop and show the fault state without charging current. The two charging indicator pins are in high resistance state, and the LED light is off. At this time, the leakage current of the reverse power supply is less than $10\mu A$. When the reverse power supply is correctly connected, TP4065 will automatically start the charging cycle.

Charging status indicator

(CHRG)

The TP4065 has one drain open state indicating output, CHRG. When the charger is in charge state, CHRG is pulled to low level, and in other states, CHRG is in high resistance state. When the battery is not connected to the

charger, CHRГ outputs a pulse signal indicating that the battery is not installed. When the external capacitor connected to the battery end is 1uF, the CHRГ flashing period is about 0.1-0.8 seconds; when the external capacitor of the BAT pin connected to the battery end is 10uF, the CHRГ flashing period is about 0.5-3 seconds.

Electrogenic adaptation

When the VCC is powered down to 4.35V, the adaptive circuit starts and automatically reduces the output current until the VCC does not decrease any more. This function can use USB or low-power power adapter or solar cell as power supply for the high-current charging system, avoiding power reset or restart.

Manual stop

The TP4065 can be put into shutdown mode at any time during the charging cycle by removing the RPROG (thus making the PROG pin float). This reduces the battery leakage current to less than 1μA and the power supply current to less than 75μA. Reconnecting the setting resistor initiates a new charging cycle. Figure 3. PROG pins float with NMOS tube off.

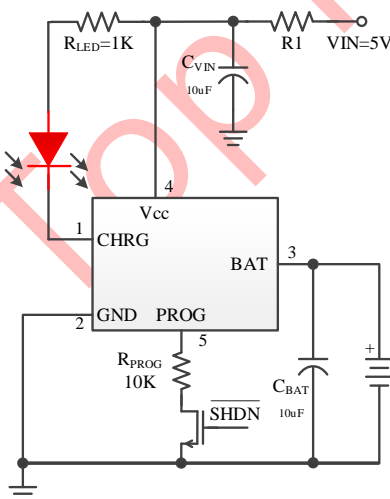
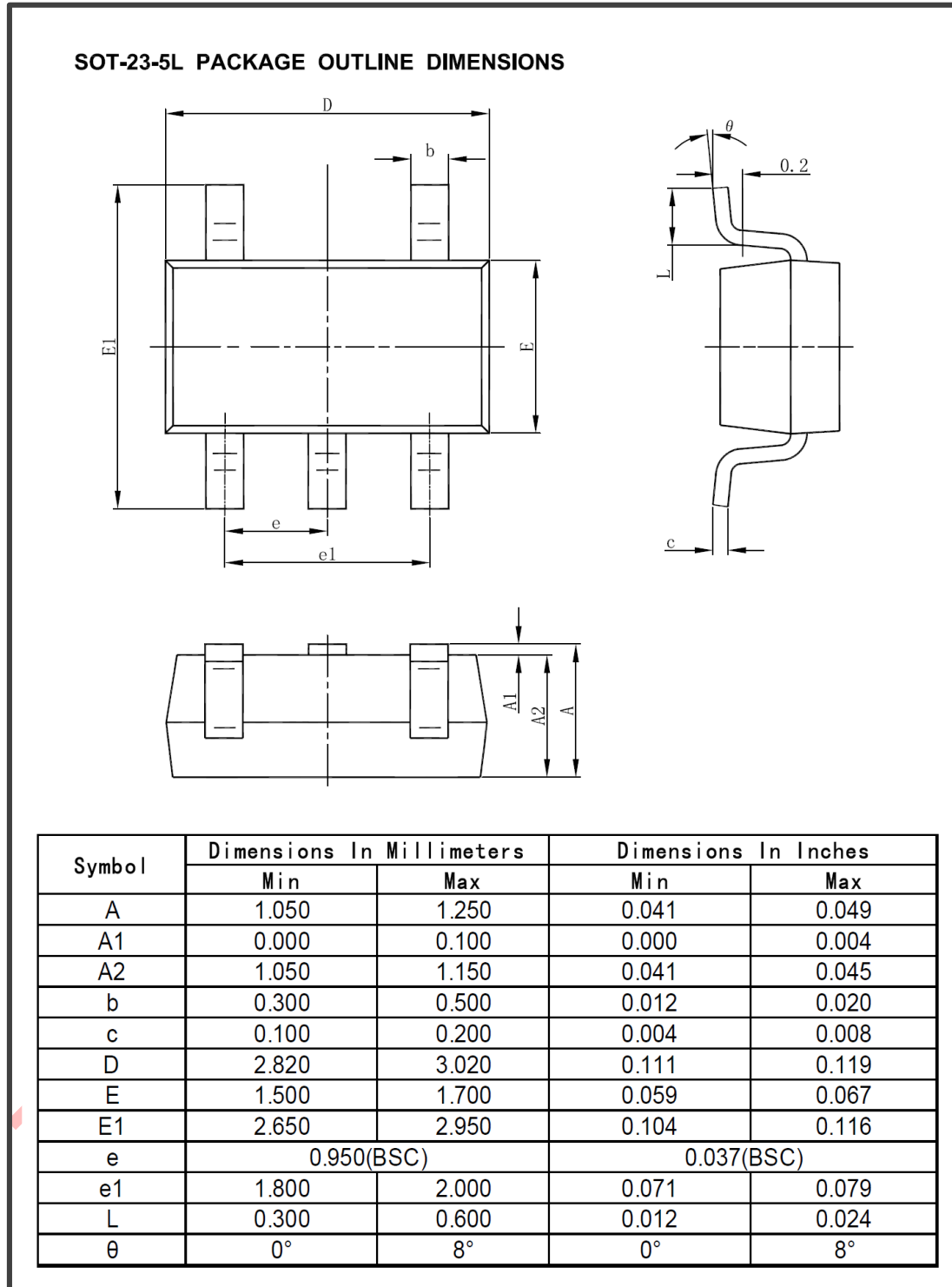

Figure 3

Automatic restart

Once the charging cycle is terminated, the TP4065 immediately employs a comparator with a filter time (tRECHARGE) to continuously monitor the voltage on the BAT pin. The charging cycle restarts when the battery voltage drops below the recharging voltage point, which roughly corresponds to 80 to 90 percent of the battery capacity. This ensures that the battery is maintained at (or near) a full charge and obviates the need to start a periodic charging cycle. During the recharging cycle, the CHRГ pin output re-enters a strong pull-down state.

Packaging description



Other Typical Applications

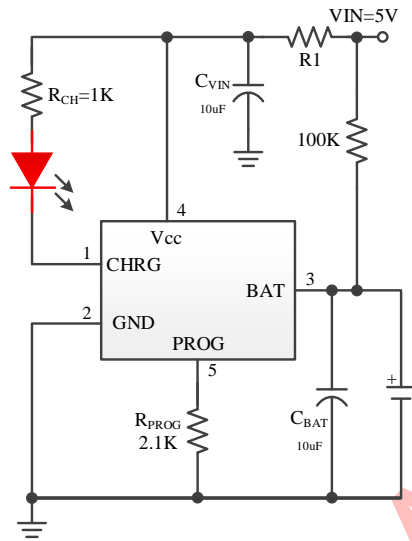

Figure 7 Single lithium battery charging application diagram when no battery red light is off