

南京拓品微电子有限公司

NanJing Top Power ASIC Corp.

数据手册

DATASHEET

TP4059

(600mA Linear lithium-ion battery
charger)

Description

TP4059 is a complete single lithium ion battery charger, with battery positive and negative reverse connection protection reverse connection, with a larger 600mA charging current, more stable current consistency. Its constant current/constant voltage linear control, SOT package and low number of external components make TP4059 an ideal choice for portable applications. TP4059 can be suitable for USB power and adapter power work.

External detection resistors and isolation diodes are not required due to the internal PMOSFET architecture and anti-reverse charging circuit. Thermal feedback can automatically adjust the charging current to limit the chip temperature during high-power operation or high ambient temperature conditions. The full voltage is fixed at 4.2V, while the charging current can be set externally via a resistor. When the battery reaches 4.2V, the charging current drops to 1/10 of the set value, and the TP4059 will automatically stop charging.

When the input voltage (AC adapter or USB power supply) is removed, the TP4059 automatically enters a low current state with the battery leakage current below 2uA. Other features of the TP4059 include a charging current monitor, undervoltage latching, automatic recharging, and two status pins to indicate the end of charging and input voltage access

characteristic

- Lithium battery reverse connection protection
- Programmable Charge Current 600mA
- Trickle, constant-current and constant-voltage control
- Preset Charge Voltage with 1% Accuracy
- Highest input can be up to 9V
- Automatic Recharge
- Available in 6-Lead SOT-23 Package
- Two Charge Status Output Pins
- C/10 Charge Termination
- For Single Cell titan acid Lithium-Ion Batteries

APPLICATIONS

- Miniature lithium battery
- Cellular phone、PAD、MP3 player

absolute maximum rating

- VCC: -0.3V~9V
- PROG: -0.3V~VCC+0.3V
- BAT: -4.2V~7V
- CHR: -0.3V~10V
- BAT Pin Current: 600mA
- PROG Pin Current: 800uA
- Maximum Junction Temperature : 145°C
- Operating Ambient Temperature Range: -40°C~85°C
- Storage Temperature Range: -65°C~125°C
- Lead Temperature(Soldering, 10sec): 260°C

Typical application

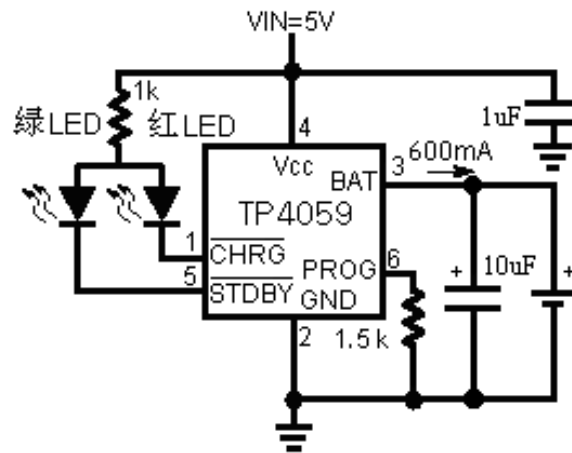

600mA Full charging cycle (600mAh)

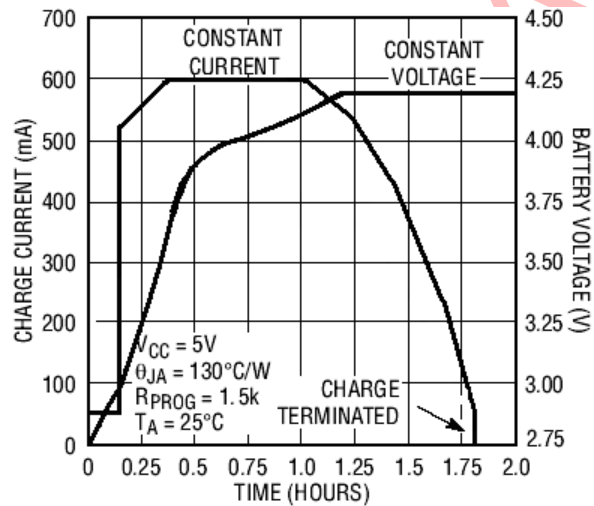

Package information

	<p>ORDER PART NUMBER</p> <p>TP4059-42-SOT236</p> <p>PART MARKING</p> <p>59bM—4.2V</p>
--	---

Pin Description

$\overline{\text{CHRG}}$ (Pin 1) : Charge status indicator of drain open circuit output. When the charger charges the battery, the pin is pulled to a low level by the internal switch, indicating that the charge is in progress. Otherwise, the pin is in a high resistance state.

GND (pin 2) : Ground

BAT (pin 3) : Charging current output. This pin provides charging current to the battery and adjusts the final floating charging voltage to 4.2V. A precise internal resistance divider of the pin sets the floating charging voltage, which is disconnected in shutdown mode.

VCC (pin 4) : Positive input supply voltage. This pin supplies power to the charger. The VCC varies between 4V and 9V and should be bypassed by at least one 1 μ F capacitor. When the VCC drops to within 30mV of the BAT pin voltage, the TP4059 enters the shutdown mode, so that the IBAT drops below 2 μ A.

$\overline{\text{STDBY}}$ (pin5): Indicating end of battery charging completion. When the battery is charged, $\overline{\text{STDBY}}$ is pulled to a low level by the internal switch, indicating that the battery is charged. In addition, $\overline{\text{STDBY}}$ pin will be in a high resistance state.

PROG (Pin 6) : Charging current setting, charging current monitoring and stopping pins. The charging current can be set by connecting a resistor RPROG with 1% accuracy between the pin and the ground. When charging in constant current mode, the pin voltage is maintained at 1V.

The PROG pin can also be used to turn off the charger. Disconnect the set resistor from the ground, and an internal 2.5 μ A current pulls the PROG pin to high level. When the voltage of this pin reaches the shutdown threshold voltage of 2.7V, the charger enters the shutdown mode, the charging stops and the input power current drops to 145 μ A. Reconnecting RPROG to ground will restore the charger to normal operation.

ELECTRICAL CHARACTERISTICS

The ● denotes specifications which apply over the full operating temperature range, otherwise specifications are at $T_A=25^{\circ}\text{C}$, $V_{CC}=5\text{V}$, unless otherwise noted.

SYMBOL	PARAMETER	CONDITIONS		MIN	TYP	MAX	UNITS
V_{CC}	Input Supply Voltage		●	4.0	5	9.0	V
I_{CC}	Input Supply Current	Charge Mode, $R_{PROG} = 10\text{k}$	●		150		μA
		StandbyMode(Charge Terminated)	●		145	500	μA
			●		120	190	μA
		Shutdown Mode (R_{PROG} Not Connected, $V_{CC} < V_{BAT}$, or $V_{CC} < V_{UV}$)				140	μA
V_{FLOAL}	Regulated Output (Float) Voltage	$0^{\circ}\text{C} \leq T_A \leq 85^{\circ}\text{C}$, $I_{BAT}=40\text{mA}$		4.158	4.2	4.242	V
I_{BAT}	BAT Pin Current (Except that $V_{BAT}=4.0\text{V}$)	$R_{PROG}=10\text{K}$, Current Mode	●	85	100	115	mA
		$R_{PROG}=2\text{K}$, Current Mode	●	365	430	495	mA
		$R_{PROG}=1.6\text{K}$, Current Mode	●	442	520	598	mA
		$R_{PROG}=1.5\text{K}$, Current Mode	●	510	600	690	mA
		Standby Mode, $V_{BAT}=4.2\text{V}$			-2.5	-6	μA
		Shutdown Mode (R_{PROG} Not Connected)			± 1	± 2	μA
	Sleep Mode, $V_{CC} = 0\text{V}$			-1	-2	μA	
I_{TRIKL}	Trickle Charge Current	$V_{BAT} < V_{TRIKL}$, $R_{PROG}=10\text{K}$	●	8	10	20	mA
V_{UV}	VCC Undervoltage Lockout Threshold	From VCC Low to High	●	3.4	3.6	3.8	V
I_{TERM}	C/10 Termination Current Threshold	$R_{PROG}=10\text{K}$	●	8	10	12	mA
		$R_{PROG}=1.66\text{K}$	●	30	40	50	mA
V_{PROG}	PROG Pin Voltage	$R_{PROG}=10\text{K}$, Current Mode	●	0.9	1.0	1.1	V
$V_{\overline{\text{CHRG}}}$	CHRG Pin Output versr Low Voltage	$I_{\overline{\text{CHRG}}} = 5\text{mA}$			0.3	0.6	V
I_{BAT}	Battery reverse leakage current	Battery reverse, $V_{IN} = 5\text{V}$		4.0	4.3	4.5	mA

operating principle

TP4059 is a single lithium-ion battery charger using constant current/constant voltage algorithm. It is capable of providing 600mA charging current (with the help of a thermally well-designed PCB layout) and an internal P-channel power MOSFET and thermal regulation circuit. No isolation diode or external current detection resistor is required; Therefore, the basic charger circuit requires only two external components. Not only that, TP4059 is also able to get working power from a USB power supply.

Normal charging cycle

A charging cycle begins when the Vcc pin voltage rises above the UVLO threshold level and a setting resistor with 1% accuracy is connected between the PROG pin and ground or when a battery is connected to the output of the charger. If the BAT pin level is lower than 2.9V, the charger enters trickle charging mode. In this mode, TP4059 provides about 1/10 of the set charging current in order to raise the current voltage to a safe level for full current charging.

When the BAT pin voltage rises to more than 2.9V, the charger enters the constant current mode and provides constant charging current to the battery at this time. When the BAT pin voltage reaches the final floating charging voltage (4.2V), TP4059 enters the constant voltage mode, and the charging current starts to decrease. When the charging current drops to 1/10 of the set value, the charging cycle ends.

Setting of charging current

The charging current is set using a resistor connected between the PROG pin and the ground. The setting resistor and charging current are calculated using the following formula:

The resistor resistance value is determined

according to the required charging current,

$$\text{Formula one: } R_{PROG} = \frac{1000}{I_{BAT}} \quad (I_{BAT} \leq 0.3A)$$

0.3A)

Example 1: When the charging current needs to be set as $I_{BAT} = 0.2A$, Equation 1 is used to calculate:

$$R_{PROG} = \frac{1000}{0.2} = 5000 \quad (\Omega)$$

$$R_{PROG} = 5k \Omega$$

Formula two:

$$R_{PROG} = \frac{1000}{I_{BAT}} \times (1.3 - I_{BAT}) \quad (I_{BAT} > 0.3A)$$

In applications larger than 0.3A, chip heat is relatively large, temperature protection will reduce the charging current, and the test current in different environments will not be completely consistent with the theoretical value calculated by the formula. In customer applications, RPROG of appropriate size can be selected according to requirements.

RPROG (k)	I _{BAT} (mA)
20k	50
10k	100
5k	180
4k	220
3k	290
2k	430
1.5k	560
1.4k	600

Charge termination

When the charging current drops to 1/10 of the set value after reaching the final floating charging voltage, the charging cycle is terminated. This condition is detected by monitoring the PROG pin with an internal filter comparator. Charging is terminated when the PROG pin voltage drops below 100mV for more

than a time (typically 1.8ms). The charging current is locked off, and TP4059 enters standby mode. At this time, the input power current drops to 145 μ A. (Note: C/10 terminates in trickle charge and heat limit modes.)

When charging, the transient load on the BAT pin will cause the PROG pin voltage to briefly drop below 100mV between when the DC charging current drops to 1/10 of the set value. The 1.8ms filtering time on the termination comparator () ensures that transient loads of this nature do not lead to premature termination of the charging cycle. Once the average charging current drops below 1/10 of the set value, TP4059 terminates the charging cycle and stops providing any current through the BAT pin. In this state, all loads on the BAT pin must be powered by the battery.

In standby mode, TP4059 continuously monitors BAT pin voltage. If the pin voltage falls below the 4.1V recharging threshold, another charging cycle begins and supplies current to the battery again. When performing a manual restart of the charge cycle in standby mode, you must cancel and then apply the input voltage, or you must turn off the charger and restart using the PROG pin.

Battery reverse connection protection function

TP4059 has the reverse connection protection function of lithium battery. The positive and negative terminals of the lithium battery are reverse connected to the TP4059 current output pin, and the TP4059 will stop and show the fault state without charging current. Both charging indicator pins are in the high resistance state, and both LED lights are off. At this time, the leakage current of the reverse connected lithium battery is less than 5mA. Connect the reverse battery correctly, and TP4059 will automatically start the charging

cycle. TP4059 after reverse connection When the battery is removed, because the capacitor potential of the BAT pin at the output end of TP4059 is still negative, the TP4059 indicator light will not immediately turn on normally, and only the correct connection of the battery can automatically activate and charge. Or wait for a long time for the electric quantity with negative potential of the BAT terminal capacitor to emit light. If the BAT terminal potential is greater than zero volt, TP4059 will display the normal battery-free indicator state. In the case of reverse connection, the supply voltage should be about 5V, and should not exceed 8V. If the power supply voltage is too high and the battery voltage is reversed, the chip voltage difference will exceed 10V. Therefore, the power supply voltage should not be too high when the battery voltage is reversed.

Charge status indicator (CHRG STDBY)

TP4059 has two drain open status indicating output terminals, $\overline{\text{CHRG}}$ and $\overline{\text{STDBY}}$. When the charger is in charge state, $\overline{\text{CHRG}}$ is pulled to the low level and in the other state, $\overline{\text{CHRG}}$ is in the high resistance state. When the battery is not connected to the charger, the $\overline{\text{CHRG}}$ output pulse signal indicates that the battery is not installed. When the external capacitor of the BAT pin at the battery connection end is 10 μ F, $\overline{\text{CHRG}}$ flicker cycle is about 0.5-2 seconds.

Automatic restart

Once the charging cycle is terminated, TP4059 immediately adopts a comparator with 1.8ms filtering time to continuously monitor the voltage on the BAT pin. When the battery voltage drops below 4.1V, which roughly corresponds to 80 to 90 percent of the battery's capacity, the charging cycle restarts. This ensures that the battery is maintained at (or near) a full charge and eliminates the need to initiate a periodic charge cycle. During the recharging cycle, the pin $\overline{\text{CHRG}}$ output re-enters a strong pull-down state and the pin $\overline{\text{STDBY}}$ output re-enters a high resistance state.

Packaging description

6-pin plastic SOT-23-6 package

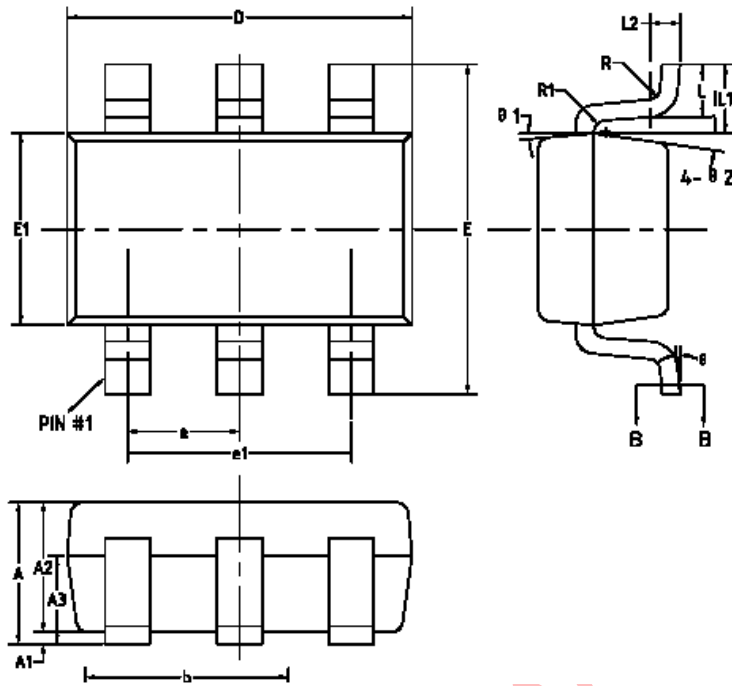

COMMON DIMENSIONS
(UNITS OF MEASURE=MILLIMETER)

SYMBOL	MIN	NOM	MAX
A	—	—	1.25
A1	0	—	0.15
A2	1.00	1.10	1.20
A3	0.60	0.65	0.70
b	0.38	—	0.50
b1	0.38	0.38	0.45
c	0.14	—	0.20
c1	0.14	0.15	0.16
D	2.828	2.928	3.028
E	2.80	2.80	3.00
E1	1.528	1.628	1.728
a	0.95BSC		
a1	1.90BSC		
L	0.35	0.45	0.60
L1	0.59REF		
L2	0.25BSC		
R	0.10	—	—
R1	0.10	—	0.20
θ	0°	—	8°
θ 1	3°	5°	7°
θ 2	6°	6°	10°

Other Typical Applications

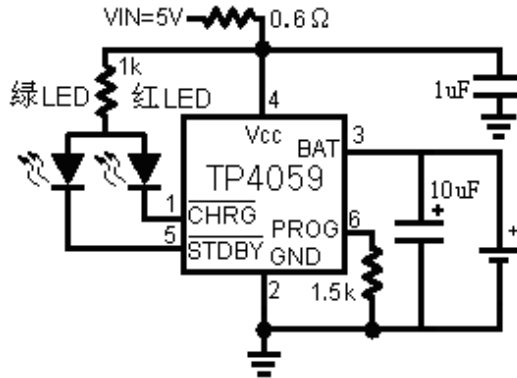

Full function single section lithium battery charger (connected to dissipation resistor)

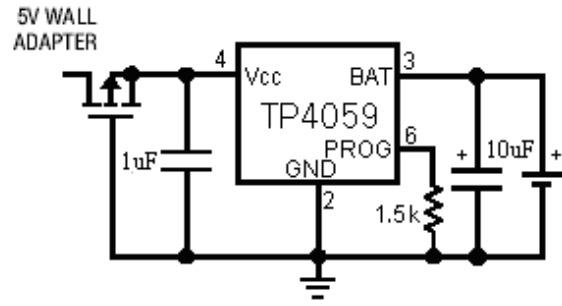

Charger with input reverse polarity protection

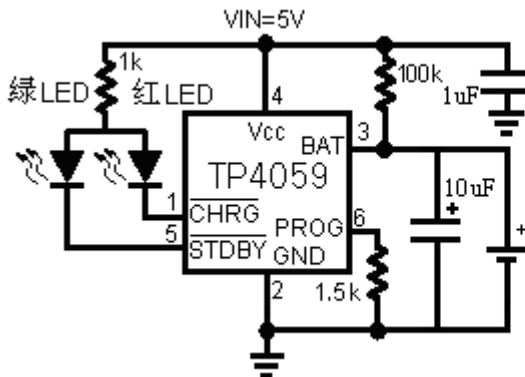

No battery, no flashing light, single lithium battery charger

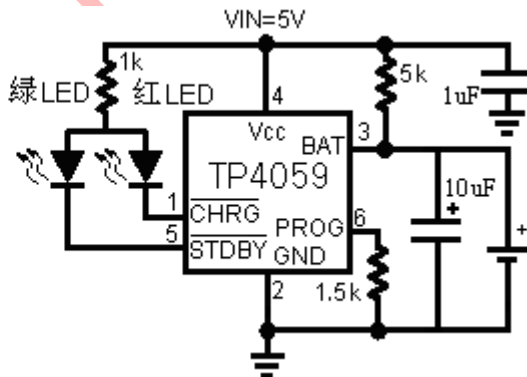

Battery free dual light off single lithium battery charger

Precautions for TP4059 test use

1. TP4059 charging current test, the BAT end of the chip (pin 3) should be directly connected to the positive electrode of the battery, not in series ammeter, ammeter can be connected to the Vcc end of the chip.
2. In order to ensure reliable use in various situations and prevent chip damage caused by spike and burr voltage, it is recommended that the Vcc end and BAT end of TP4059 application are respectively connected with 1uF and 10uF capacitors, if possible, they can also be connected with a 0.1U ceramic capacitor. All capacitors should be located close to the chip pin, not too far away.
3. using SOT23 package, high current application (above 400mA) heat dissipation effect is not good may cause the charging current is protected by temperature and reduce. The customer can not connect the dissipation resistance, if the current cannot meet the requirements, please design the heat dissipation resistance according to the actual power supply voltage, the chip Vcc terminal input voltage of 4.6V is the best, can get a larger charging current, the general heat dissipation resistance is 0.5 to 1 ohm. The same good PCB layout can effectively reduce the impact of temperature on current in high current charging applications.