

TP5400 1000mA Li-Ion Battery Charger and 5V 1A boost

DESCRIPTION

TP5400 is a Li-Ion battery charger and 5V boost chip used for mobile power supply. High precision voltage and charge current regulator, pre-charge, charge indicator, charge circle termination and other functions are all integrated into a single chip. Maximum charge current can reach 1 A. Boost circuit uses CMOS DC/DC boost converter working in VFM switching mode, which has very low no-load current. Besides, It has limited no-load dissipation, up to 1000mA boost output current, and no external button is needed, which means it can work automatically when it is connected to supply.

No blocking diode is required due to the internal PMOSFET architecture and have prevent to negative Charge Current Circuit. Thermal feedback regulates the charge current to limit the die temperature during high power operation or high ambient temperature. The charge voltage is fixed at 4.2V, and the charge current can be programmed externally with a single resistor. The chip automatically terminates the charge cycle when the charge current drops to 1/5th the programmed value after the final float voltage is reached.

Boost output capacity reaches 5V/1A due to the internal PMOSFET architecture and limited internal resistor. TP5400 only needs a limited external devices to work properly because of integration. TP5400 other features include over temperature protection, boost input current limit circuit, boost output current adjustment, rapid reaction and over-current shut down.

FEATURES

- Programmable Charge Current Up to 1.2A, Typically 1000mA
- Boost Current Up to 1.5A ($V_{bat}=3.8V$), Typically 1000mA ($V_{bat}=3.3V$)
- Specified for Mobile Power Supply with Single Li-Ion Battery
- High Boost Efficient: 88%(Typ)
- Constant Current & Constant Voltage Operation, Heat Regulating Function makes High Charge Efficient without the Danger of Overheating
- 4.2V + -1% charging voltage control Accuracy
- 5V \pm 2.5% boost voltage control Accuracy
- Input Voltage Up to 9V
- two Charge Status Output Pins
- C/5 Charge Termination
- 2.9V Trickle Charge Threshold
- Soft-Start Limits Inrush Current
- Automatic Frequency Adjustment (VFM), adjust to Variety Loads (No-load Current less than 10uA when Supply Voltage is 5V), No External Button is Required for Start, and Terminates Boost Circuit when Battery Voltage is Low(less than 3V)
- Available Radiator in 8-Lead SOP/MSOP Package, the Radiator need connect GND or impending

ABSOLUTE MAXIMUM RATINGS

- Input Supply Voltage(V_{CC}): -0.3V~10V
- PROG: -0.3V~ $V_{CC}+0.3V$
- BAT: 0V~7V
- LX: -2V~10V
- V_{OUT} : -0.3V~10V
- CHRG: -0.3V~10V
- BAT Short-Circuit Duration: Continuous
- BAT Pin Current: 1200mA
- Maximum Boost Output Current: 1.8A/5V
- Maximum Junction Temperature: 145°C
- Operating Ambient Temperature Range: -40°C~85°C
- Storage temperature range: -65°C~125°C
- Lead Temp.(Soldering, 10sec): 260°C

APPLICATIONS

- Mobile Power Supply

Complete Charge Cycle (1000mAh Battery)

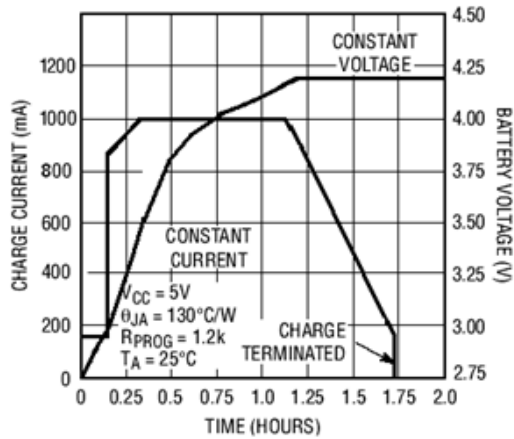

PACKAGE/ORDER

<p>Pinout: 1 VOUT, 2 CHRG, 3 PROG, 4 STDBY, 5 VCC, 6 BAT, 7 GND, 8 LX.</p>	<p>Orders Model</p> <p>TP5400-ESOP8</p> <p>Pictures</p>
--	---

TYPICAL APPLICATIONS

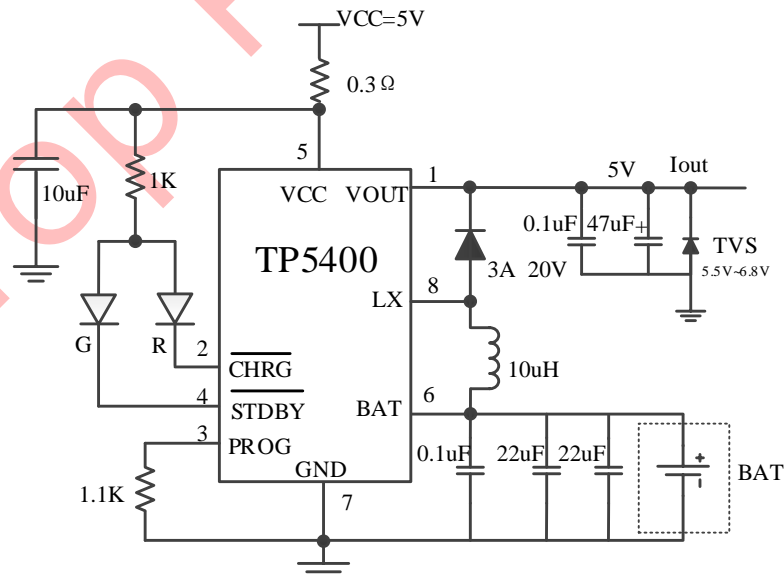

1000mA Single Cell Li-Ion Charger or 5V Output Boost Converter

ELECTRICAL CHARACTERISTICS

The ● denotes specifications which apply over the full operating temperature range, otherwise specifications are at TA=25°C, VCC=5V, unless otherwise noted.

SYMBOL	PARAMETER	CONDITIONS		MIN	TYP	MAX	UNITS
V _{CC}	Input Supply Voltage		●	4.0	5	9.0	V
I _{CC}	Input Supply Current	Charge Mode, R _{PROG} = 10K Standby Mode(Charge Terminated) Shutdown Mode (R _{PROG} Not Connected, V _{CC} < V _{BAT} , or V _{CC} < V _{UV}) Boost start	● ● ●		150 40 40 40 0	500 100 100 100	μA μA μA μA μA
V _{FLOAT}	Regulated Output (Float) Voltage	0°C ≤ T _A ≤ 85°C, I _{BAT} = 40mA		4.158	4.2	4.242	V
I _{BAT}	BAT Pin Current(Except for instructions, V _{bat} =4.0v)	R _{PROG} =1.5K, Current Mode R _{PROG} =1.1K, Current Mode Standby mode, V _{BAT} =3.8V	● ● ●	665 900	740 1000 -10	815 1100 -100	mA mA μA
I _{TRIKL}	Trickle Charge Current	V _{BAT} < V _{TRIKL} , R _{PROG} = 1.5K	●	150	200	250	mA
V _{TRIKL}	Trickle Charge Threshold Voltage	R _{PROG} = 1.5K, V _{BAT} Rising		2.8	2.9	3.0	V
V _{UV}	V _{CC} Undervoltage Lockout Threshold	From V _{CC} Low to High	●	3.4	3.6	3.8	V
I _{TERM}	C/5 termination current limit	R _{PROG} = 1.5K	●	150	200	250	mA
V _{PROG}	PROG Pin Voltage	R _{PROG} = 1.5K, Current Mode	●	0.9	1.0	1.1	V
V _{CHRG}	CHRG Pin output low voltage	I _{CHRG} = 5mA			0.3	0.6	V
V _{STDBY}	STDBY Pin output low	I _{STDBY} = 5mA			0.3	0.6	V
ΔV _{RECHRG}	Recharge Battery Threshold Voltage	V _{FLOAT} - V _{RECHRG}		100	150	200	mV
T _{LIM}	Junction Temperature in Constant Temperature Mode				120		°C
Charging R _{ON}	Power FET "ON" Resistance (Between V _{CC} and BAT)				450		mΩ
t _{SS}	Soft-Start Time	I _{BAT} = 0 to I _{BAT} = 1100V/R _{PROG}			20		ms
t _{TERM}	Termination Comparator Filter Time	I _{BAT} Falls Below I _{CHG} /5		0.8	1.8	4	ms
V _{BatLOW}	Battery Undervoltage Protection	V _{bat} Drops From 3.6V	●	2.9	3	3.1	V
V _{BatHigh}	Battery Undervoltage Protection Unlocked	V _{bat} Rises From 2.7V	●	3.2	3.3	3.4	V
F _{OSC}	Oscillation Frequency			300	400	500	KHZ

Dty	MaximumDuty cycle			75		%
η_{boost}	Boost efficiency	$V_{BAT}=3.8V$ $I_{OUT}=500mA$		90		%
η_{boost}	Boost efficiency	$V_{BAT}=3.8V$ $I_{OUT}=1000mA$		88		%
Boost R_{ON}	Boost NMOS Tube Internal Resistance	$V_{LX}=0.4V$		120		m Ω
I_{Lxleak}	Boost NMOS Leakage Current	$V_{LX}=6V$			1	μA
I _{lmt_nmos}	Boost Switch Current Limiting			4	4.5	A

Pin Function

1	VOUT	Output voltage detection pin
2	\overline{CHRG}	Open-Drain Charge Status Output
3	PROG	Charge Current Program, Charge Current Monitor and Shutdown Pin
4	\overline{STDBY}	Charge indicator status
5	VCC	The positive input terminal of the input voltage of the charger
6	BAT	Charge Current Output
7	GND	Power Ground
8	LX	The output of the internal power tube of the boost circuit

Block diagram

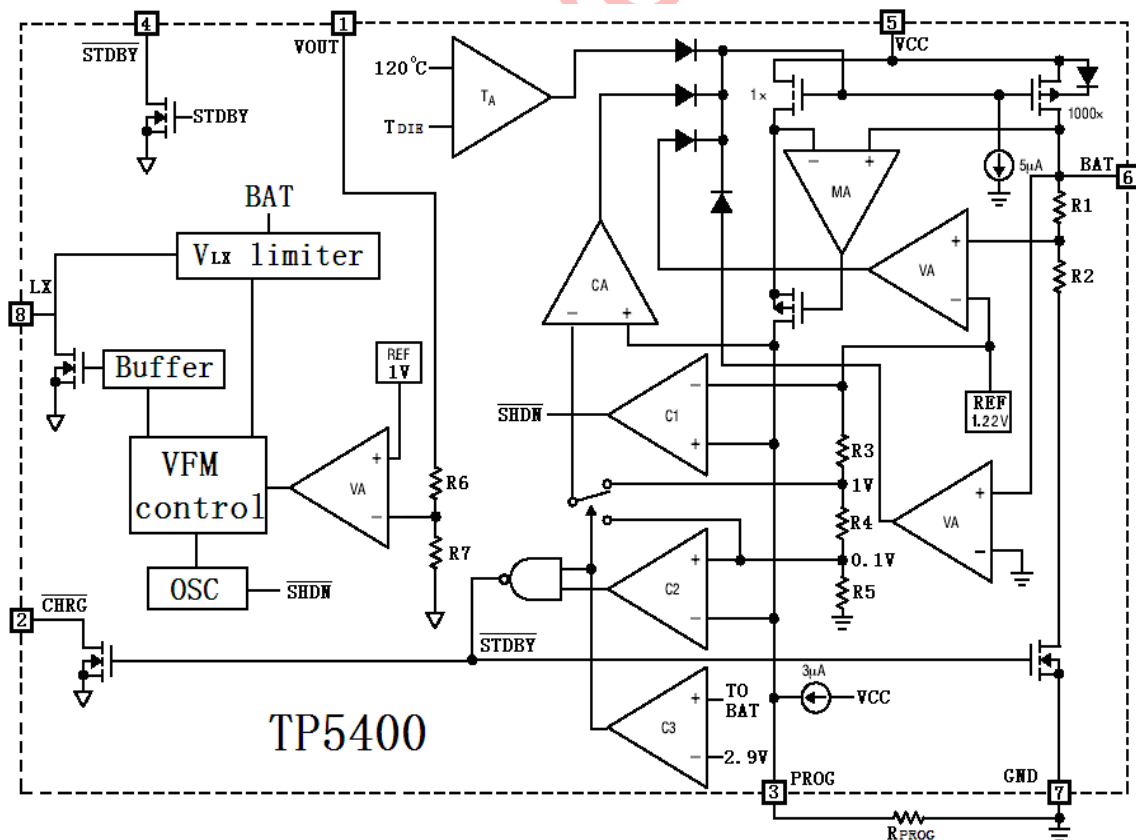

Normal Charge Cycle

A charge cycle begins when the voltage at the V_{CC} pin rises above the UVLO threshold level and a 1% program resistor is connected from the PROG pin to ground or when a battery is connected to the charger output. If the BAT pin is less than 2.9V, the charger enters trickle charge mode. In this mode, the TP5400 supplies approximately 1/5 the programmed charge current to bring the battery voltage up to a safe level for full current charging.

When the BAT pin voltage rises above 2.9V, the charger enters constant-current mode, where the programmed charge current is supplied to the battery. When the BAT pin approaches the final float voltage (4.2V), the TP5400 enters constant-voltage mode and the charge current begins to decrease. When the charge current drops to 1/5 of the programmed value, the charge cycle ends.

Programming Charge Current

The charge current is programmed using a single resistor from the PROG pin to ground. The battery charge current is 1100 times the current out of the PROG pin. The program resistor and the charge current are calculated using the following equations:

$$R_{PROG} = \frac{1100}{I_{BAT}}$$

In the customer's application, the relationship between RPROG and charging current can be determined by referring to the following table:

RPROG (Ω)	I _{BAT}
10k	130mA
5k	245mA
2k	560mA
1.5k	740mA
1.1k	1000mA

Charge Termination

A charge cycle is terminated when the charge current falls to 1/5th the programmed value after the final float voltage is reached. This condition is detected by using an internal, filtered comparator to monitor the PROG pin. When the PROG pin voltage falls below 200mV for longer than t_{TERM} (typically 1.8ms), charging is terminated. The charge current is latched off and the TP5400 enters standby mode, where the input supply current drops to 40μA. (Note: C/5 termination is disabled in trickle charging and thermal limiting modes). When charging, transient loads on the BAT pin can cause the PROG pin to fall below 200mV for short periods of time before the DC charge current has dropped to 1/5th the programmed value. The 1.8ms filter time (t_{TERM}) on the termination comparator ensures that transient loads of this nature do not result in premature charge cycle termination. Once the average charge current drops below 1/5th the programmed value, the TP5400 terminates the charge cycle and ceases to provide any current through the BAT pin. In this state, all loads on the BAT pin must be supplied by the battery.

The TP5400 constantly monitors the BAT pin voltage in standby mode. If this voltage drops below the 4.1V recharge threshold (V_{RECHRG}), another charge cycle begins and current is once again supplied to the battery. To manually restart a charge cycle when in standby mode, the input voltage must be removed and reapplied, or the charger must be shut down and restarted using the PROG pin.

Undervoltage Lockout (UVLO)

An internal undervoltage lockout circuit monitors the input voltage and keeps the charger in shutdown mode until V_{CC} rises above the undervoltage lockout threshold. The UVLO circuit has a built-in hysteresis of 200mV. Furthermore, to protect against reverse current in the power MOSFET, the UVLO circuit keeps the charger in shutdown mode if V_{CC} falls to within 30mV of the battery voltage. If the UVLO comparator is tripped, the charger will not come out of shutdown mode until V_{CC} rises 50mV above the battery voltage.

Automatic Recharge

Once the charge cycle is terminated, the TP5400 continuously monitors the voltage on the BAT pin using a comparator with a 1.8ms filter time ($t_{RECHARGE}$). A charge cycle restarts when the battery voltage falls below 4.1V (which corresponds to approximately 80% to 90% battery capacity). This ensures that the battery is kept at or near a fully charged condition and eliminates the need for periodic charge cycle initiations. CHRG output enters a strong pulldown state during recharge cycles.

Boost Discharge Circuit

Boost circuit stores energy by the inductor and then discharges with the input power together supply to obtain the output voltage higher than the input voltage. As shown below:

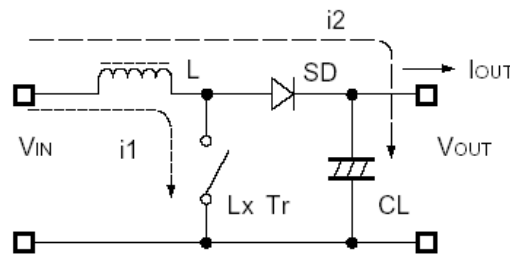

When the VCC pin is not connected to the power supply and the Li-Ion battery voltage is in the range of 3V-4.2V, the boost circuit starts automatically and the 5V constant voltage source is continuously output. When the BAT voltage is 3V-4.2V and the input power supply V_{CC} is less than 3.8V, or $V_{CC} < V_{bat} + 50mV$ and the PROG pin is left floating, the boost operation will also work.

Package description

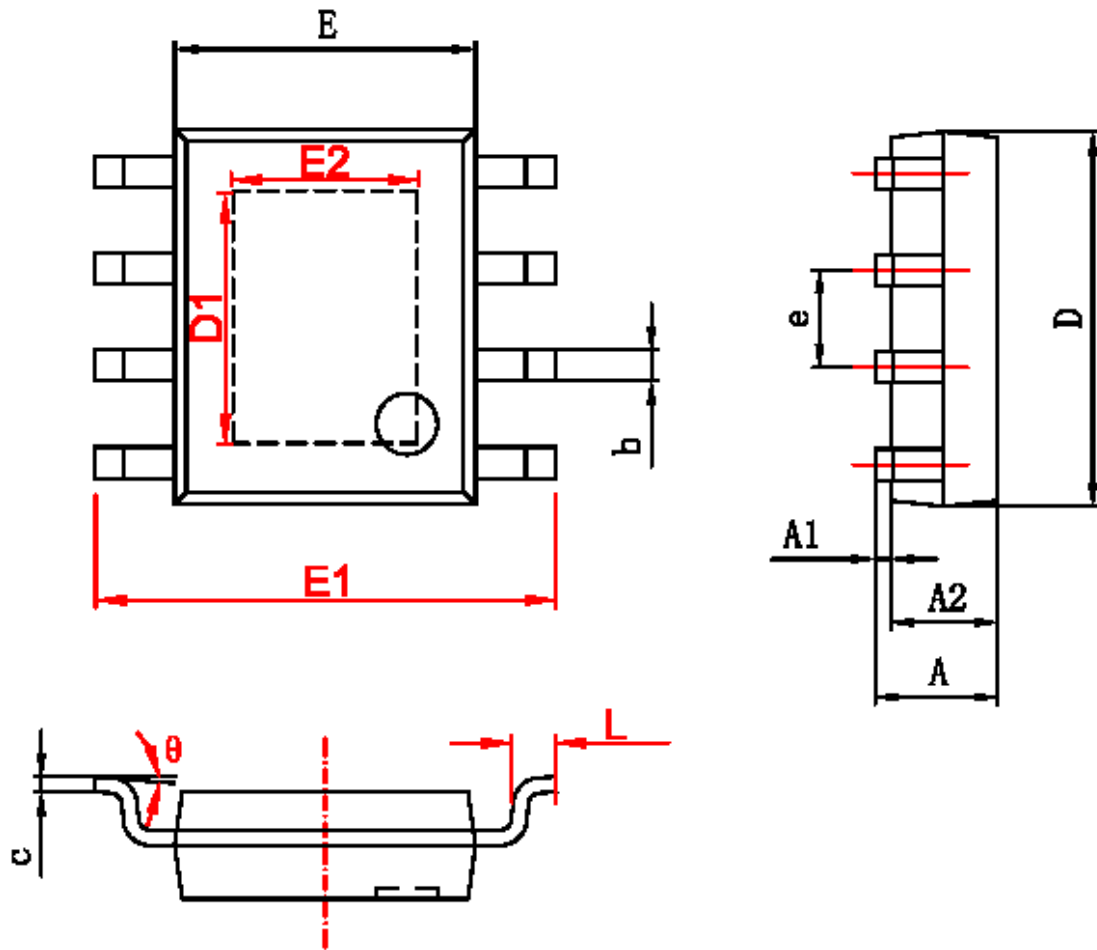

character	Dimensions In Millimeters		Dimensions In Inches	
	Min	Max	Min	Max
A	1.350	1.750	0.053	0.069
A1	0.050	0.150	0.004	0.010
A2	1.350	1.550	0.053	0.061
b	0.330	0.510	0.013	0.020
c	0.170	0.250	0.006	0.010
D	4.700	5.100	0.185	0.200
D1	3.202	3.402	0.126	0.134
E	3.800	4.000	0.150	0.157
E1	5.800	6.200	0.228	0.244
E2	2.313	2.513	0.091	0.099
e	1.270 (BSC)		0.050 (BSC)	
L	0.400	1.270	0.016	0.050
θ	0°		8°	

NOTICE

- 1、To prove reliability, we advice to locate capacitors of Vcc, Bat and Vout near the pins as close as possible. Besides, a 0.1uF ceramic capacitor should be paralleled next to the pins as well.
- 2、It is recommended to use two 22uF capacitors in parallel at the BAT end, and the capacitance value at the VOUT end should not be less than 47 μ F (too small capacitance value will cause the chip to work unstable, and it is strongly required to use tantalum capacitors or electrolytic capacitors at the VOUT end), and connect a 5.5V~6.8V TVS diode to make it have better frequency characteristics. In addition, because the LX switch drive transistor produces a peak voltage when it is turned off, the capacitance value of the capacitor is at least three times the design output voltage.
- 3、Inductance value recommended 3.3-22uH, typically 10uH.
- 4、External diode recommended Schottky diode, SS32 is recommended.
- 5、The line between Vout pin and load should be as short as possible because of large output current.
- 6、Gnd pin must be well-linked to ground or the chip's operation may be instable.